

MINOLTA

Digital Camera

Dimâge EX

E Camera Instruction Manual



TABLE OF CONTENTS

Thank you for purchasing this Minolta product. Your new digital camera has extraordinary features that expand your image capturing horizons.

- Megapixel (1.5 million pixels), progressive scan Sony Wfine CCD™ with primary colour filter.
- High quality 2 inch colour LCD monitor with Live View display.
- Digita™ Operating Environment from FlashPoint Technology.
- Uses removable CompactFlash™ cards for storage, so there's no limit on how many shots you can take.
- Detachable, compact lens unit. The Zoom 1500 lens unit features a focal length of 7 - 21mm (approximate equivalent to 38 - 115mm in 35mm format) with Macro capability. The Wide 1500 is a 5.2mm f/1.9 lens until (approximate equivalent to 28mm in 35mm format).
- Fast capture speed, capable of 3.5 frames per second in Burst mode.
- IrDA version 1.0 wireless communication with your IrDA-capable personal computer (running Windows 95® or Windows 98®).

| | |
|-----------------------------------|---|
| For Proper and Safe Use | 4 |
| Before You Begin | 5 |

GETTING STARTED RIGHT AWAY

| | |
|-----------------------|---|
| Preparation | 6 |
| Recording | 6 |
| Play/Review | 8 |
| Deleting | 9 |

NAMES OF PARTS

| | |
|-------------------------------|----|
| Camera Body - Front | 11 |
| Camera Body - Back | 12 |
| LCD Monitor | 14 |
| Viewfinder | 14 |

BEFORE RECORDING

| | |
|--|----|
| Attaching the Strap | 16 |
| Inserting Batteries | 17 |
| Low Battery Indicator | 18 |
| Auto Power Off | 18 |
| Setting the Date/Time | 19 |
| Compact Flash Card | 21 |
| Adjusting the LCD Monitor | 23 |
| Turning the LCD Monitor On/Off | 23 |
| Adjusting the LCD Monitor Brightness | 23 |
| Adjusting the Camera Display | 24 |
| Overlay Button | 24 |
| Status Button | 25 |

RECORD MODE

| | |
|-------------------------------|----|
| Record Mode Screen | 27 |
| Taking Pictures | 27 |
| Burst Image Capture | 31 |
| Timelapse | 33 |
| Focus | 36 |

Digital Camera: Dimâge EX



Tested to comply with FCC standards.

FOR HOME OR OFFICE USE

This device complies with Part 15 of the FCC Rules. Operation is subject to the following two conditions: (1) This device may not cause harmful interference, and (2) this device must accept any interference received, including interference that may cause undesired operation.
Tested by the Minolta Corporation
101 Williams Drive, Ramsey, New Jersey 07446, U.S.A.

This Class B digital apparatus complies with Canadian ICES-003.

Cet appareil numérique de la classe B est conforme à la norme NMB-003 du Canada.

Do not remove the ferrite cores from the video and serial cables.

* Wfine CCD™ is a trademark or registered trademark of Sony Corporation.

* Digita™ and the Digita™ logo are licensed trademarks or registered trademarks of FlashPoint Technology, Inc. in the U.S. and other countries.

* Other corporate names and product names are the trademarks or registered trademarks of their respective companies.

TABLE OF CONTENTS

RECORD MODE - CONTINUED

| | |
|---|-----|
| Focus Lamp/No Focus Indicator | .36 |
| Focus Range | .36 |
| Special Focus Situations | .37 |
| Focus Hold | .37 |
| Built-in Flash | .38 |
| Changing the Flash Mode | .38 |
| Flash Range | .39 |
| Digital Scene Selector | .40 |
| Macro (Zoom 1500 Lens Only) | .42 |
| Exposure Compensation | .43 |

RECORD MODE MENUS

| | |
|---|-----|
| Record Mode Menus | .45 |
| Selecting the Image Size | .46 |
| Selecting Image Quality | .47 |
| Selecting Colour or B&W | .49 |
| Self Timer | .50 |
| Selecting the Burst Capture Rate | .52 |
| Timelapse Interval and Total Images | .53 |
| White Balance | .55 |
| Bracket | .56 |
| Instant Review | .58 |
| System Sounds | .59 |
| Counter Reset | .60 |
| Camera Name | .61 |
| Formatting Compact Flash Cards | .62 |

PLAY MODE

| | |
|--|-----|
| Play Mode Screen | .64 |
| Playback | .64 |
| Zoom In - Zoom Out | .66 |
| Expand/Collapse - Open/Close | .67 |
| Play Button | .68 |

PLAY MODE MENUS

| | |
|-------------------------|-----|
| Slideshow | .70 |
| Playback Rate | .72 |

REVIEW MODE

| | |
|--|-----|
| Review Mode Screen | .74 |
| Reviewing/Selecting Images | .75 |
| Marking Images | .76 |
| Category | .78 |
| Expand/Collapse - Open/Close | .80 |

REVIEW MODE MENUS

| | |
|-------------------------------------|-----|
| Review Mode Menus | .83 |
| Deleting Images | .84 |
| Group | .86 |
| Creating a New Group | .86 |
| Adding to a Group | .88 |
| Dissolving a Group | .89 |
| Protecting Images | .90 |
| Camera to Camera Transfer | .91 |
| Find By Date | .94 |
| Find By Category | .96 |
| Language | .97 |
| Video Mode | .98 |

APPENDIX

| | |
|--|-------------|
| Accessories | .101 |
| Custom Scripts | .102 |
| Applications | .103 |
| File Size | .104 |
| Card Capacity | .105 |
| Troubleshooting | .106 |
| Care and Storage | .109 |
| Technical Details | .112 |
| LATE-BREAKING INFORMATION | .114 |
| User Technical Support | .117 |
| New Dimâge EX Operating Environment Version 2 | .120 |

Read and understand all warnings and cautions before using this product.



Batteries may become hot or explode due to improper use.

- Use only the batteries specified in this instruction manual.
- Do not install the batteries with the polarity (+/-) reversed.
- Do not subject batteries to fire or high temperatures.
- Do not attempt to recharge, short, or disassemble.
- Do not mix batteries of different types, brands, or ages.

Use caution, accidents may occur when using this product near young children.

Keep batteries or things that could be swallowed away from young children. Contact a doctor immediately if an object is swallowed.

Immediately remove the batteries and discontinue use if...

- the camera is dropped or subjected to an impact in which the interior is exposed.
- the product emits a strange smell, heat, or smoke.

Do not walk while looking at the monitor.

Do not disassemble. Electric shock may occur if a high voltage circuit inside the camera is touched.

Take your camera to a Minolta Service Facility when repairs are required.

The heat of the camera rises with extended periods of use. Use caution when handling the camera or removing the batteries and compact flash card.

Check the packing list before you begin. If some parts are missing, contact your Camera dealer or a Minolta Service Facility listed on the back cover of this manual.

Dimâge EX Camera body
Zoom 1500 lens unit or Wide 1500 lens unit
Camera Case CC-EX1
Hand Strap HS-V1
Video Cable VC-EX1
Compact Flash Card
AA Alkaline Batteries (4)
PC Serial Adapter SC-EX1#
Macintosh Adapter MA-EX1
Dimâge EX CD-ROM
Instruction Manuals (Camera and Software) CD ROM
Warranty and Product & Software Registration Card
Adobe™ Photoshop™ LE

Data saved in flash memory may be irrecoverably lost or damaged for unexpected reasons (static electricity, electric noise, a camera error, or other malfunctions). Back-up the data recorded in the camera. Minolta is not responsible if data stored in the camera is irretrievably lost or damaged.

PREPARATION - See pages 17 and 21 for detailed information.

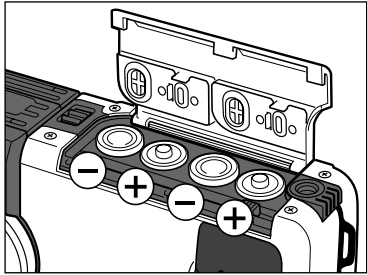

1 Insert the batteries.

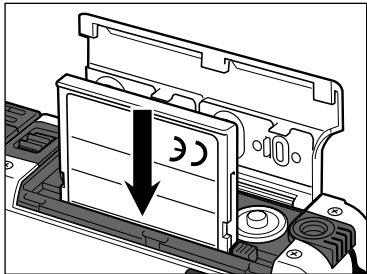

2 Insert the compact flash card.

RECORDING - See pages 27 – 30 for detailed information.

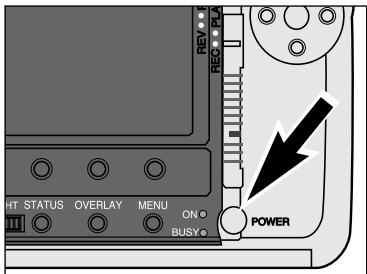

1 Press the main switch to turn the camera on.

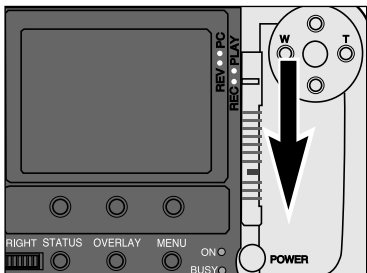

2 Set the camera to Record mode.
 • Slide the Mode switch to REC.

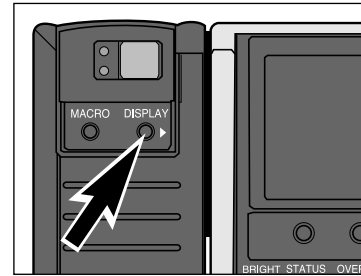

3 Press the Display button to turn on the LCD monitor.

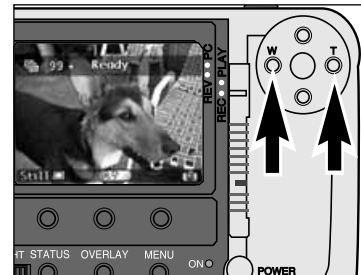

4 Frame the image in either the LCD monitor or viewfinder.
 • Place the viewfinder's focus frame on the subject or center the subject in the LCD monitor.
 • Zoom 1500: Press the Left button (W) or Right button (T) to zoom in on the subject as desired.



5 Press the shutter-release button part-way down.
 • The green focus lamp will glow if focus is confirmed.
 • The orange flash lamp will glow if the flash is charged and ready.
 • In low-light situations the AF illuminator (flash) will fire to aid detection focus.

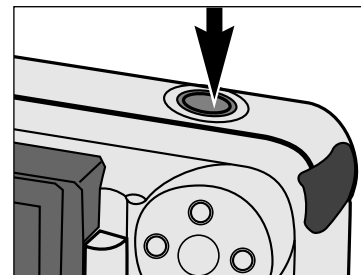

6 Press the shutter-release button all the way down to take the picture.

PLAY/REVIEW

- See pages 64 and 83 for detailed information.

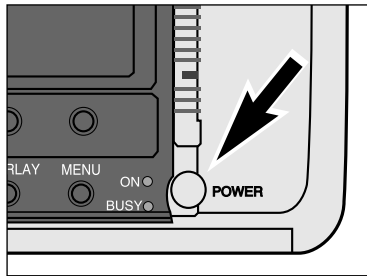

1 Turn the camera on.

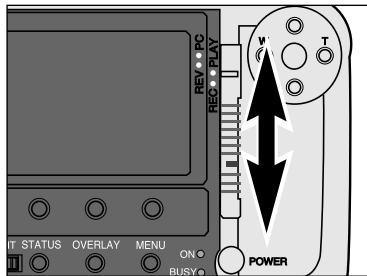

2 Set the camera to Play mode.
 • Slide the mode switch to PLAY.

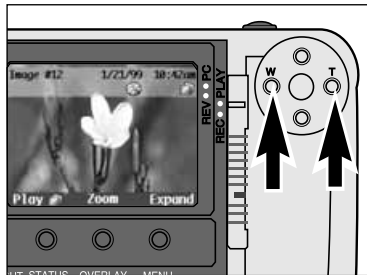

3 Press the Left and Right buttons to scroll through the images.

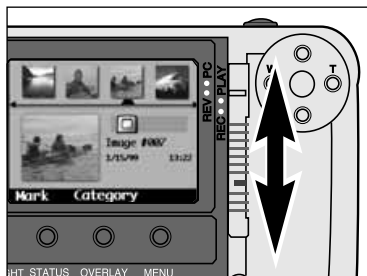

4 Set the camera to Review mode.
 • Press the lock button while sliding the mode switch to REV.

- The LCD monitor changes to the Review mode screen.
- Small thumbnails, cropped square, are lined chronologically at the top of the screen.
- The large thumbnail is a preview of the small thumbnail selected by the pointer.

SELECTED IMAGE: The image displayed as a large thumbnail.

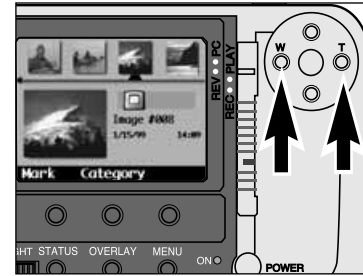

5 Press the Left and Right buttons to scroll through the images.

DELETING

- See pages 84 – 85 for detailed information.

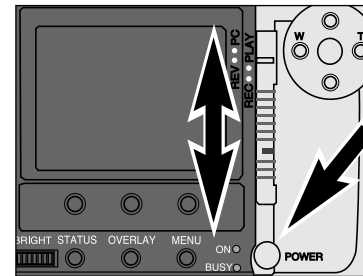

1 Turn the camera on.

2 Set the camera to Review mode.
 • Press the lock button while sliding the mode switch to REV.

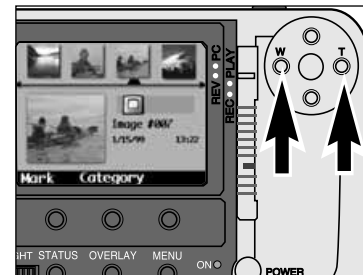

3 Press the Left and Right buttons to select the desired image.
 • SELECTED IMAGE: The image displayed as a large thumbnail.

4 Press the Mark soft key.
 • A notch will appear at the bottom-right corner of the thumbnail.

✎ Mark multiple images by repeating steps 3 and 4.



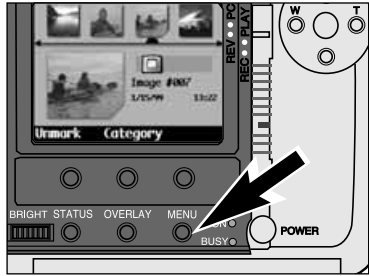

- 5 Press the Menu button.**
- The Review mode menu screen will appear.



- 6 Press the Left or Right button until the Edit menu is displayed, then press the Down button until Delete is highlighted.**



- 7 Press the Delete soft key.**
- A confirmation screen will appear.

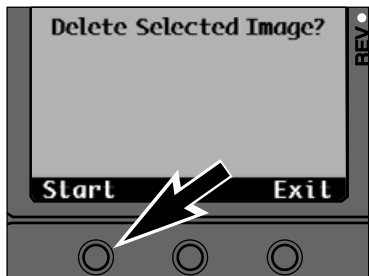

- 8 Press the Start soft key.**
- After deleting the Marked image(s), the screen will return to the Review mode screen.

CAMERA BODY - FRONT

* Do not touch.

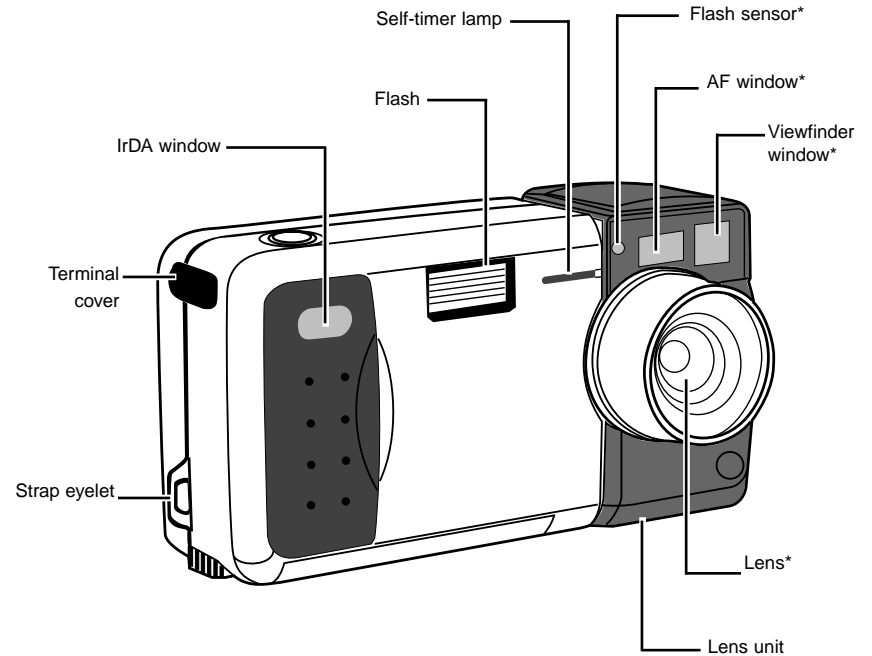

Under the Terminal Cover

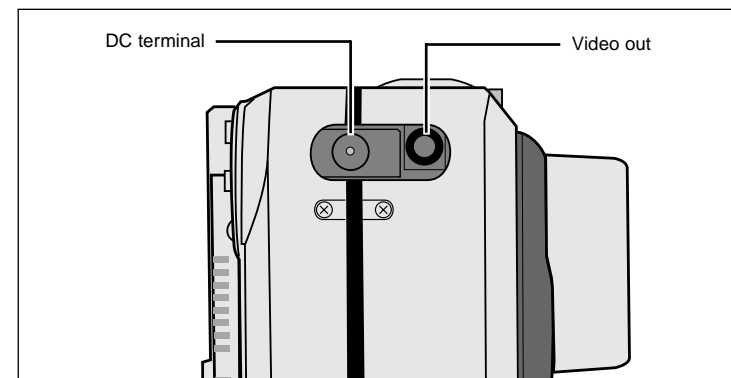

CAMERA BODY - BACK

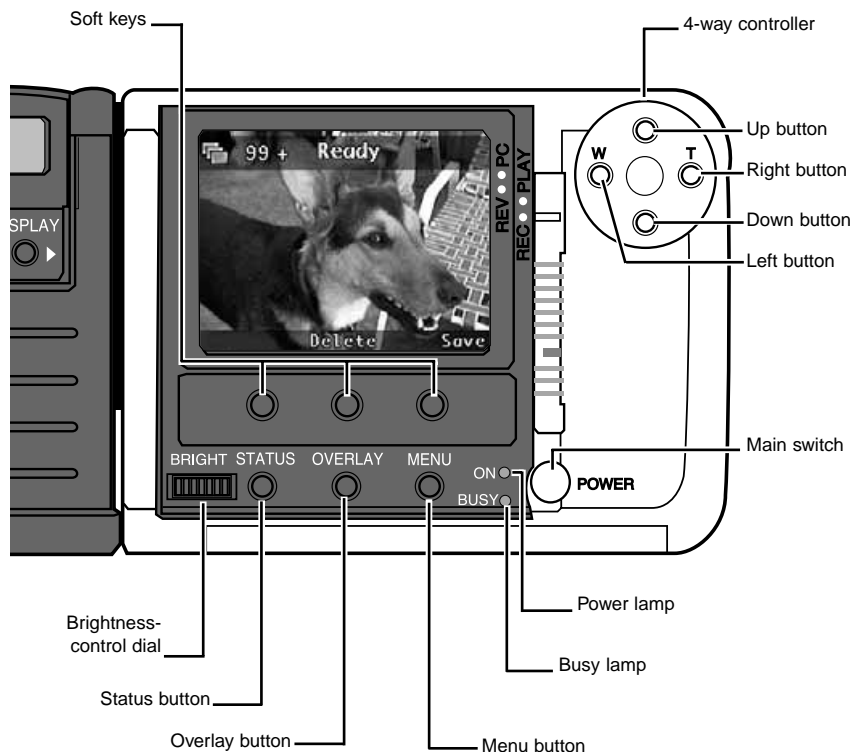

SOFT KEYS

The function of the soft keys depend on the current soft key label on the LCD Monitor (p. 14). In the display above, the function of the right soft key would be to save the image, the function of the middle soft key would be to delete the image, and the left soft key would be inactive.

4-WAY CONTROLLER (UP, DOWN, LEFT, AND RIGHT BUTTONS)

In Record mode, the Up and Down buttons control Exposure Compensation, while the Left and Right buttons (with the Zoom 1500) control the focal length. In other modes and in the menu function, the 4-way controller helps you navigate through menus and images.

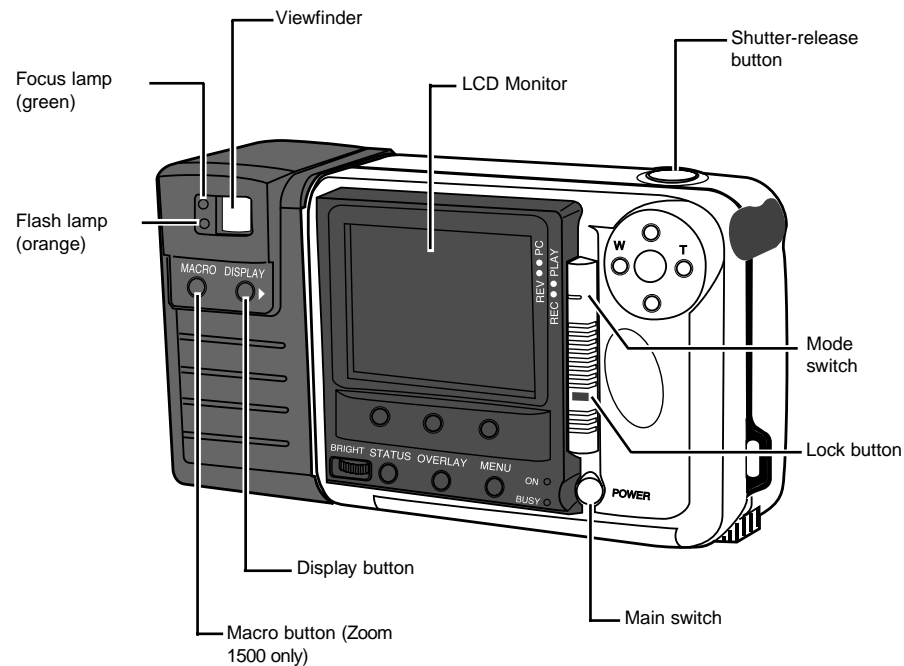

Camera Bottom

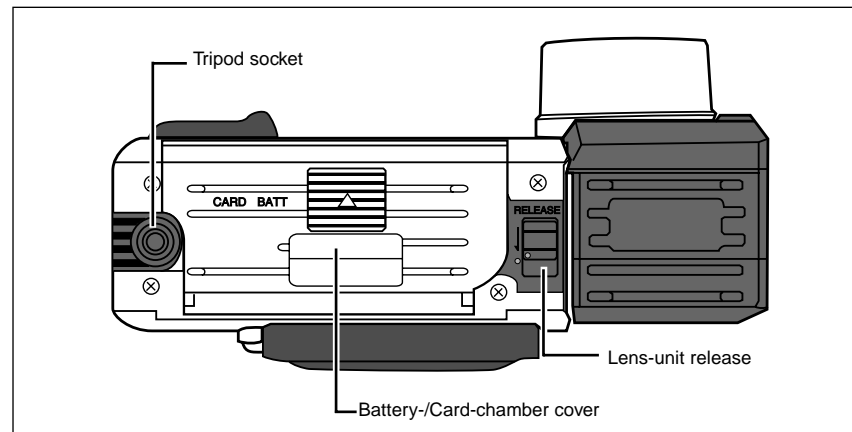

NAMES OF PARTS

LCD MONITOR

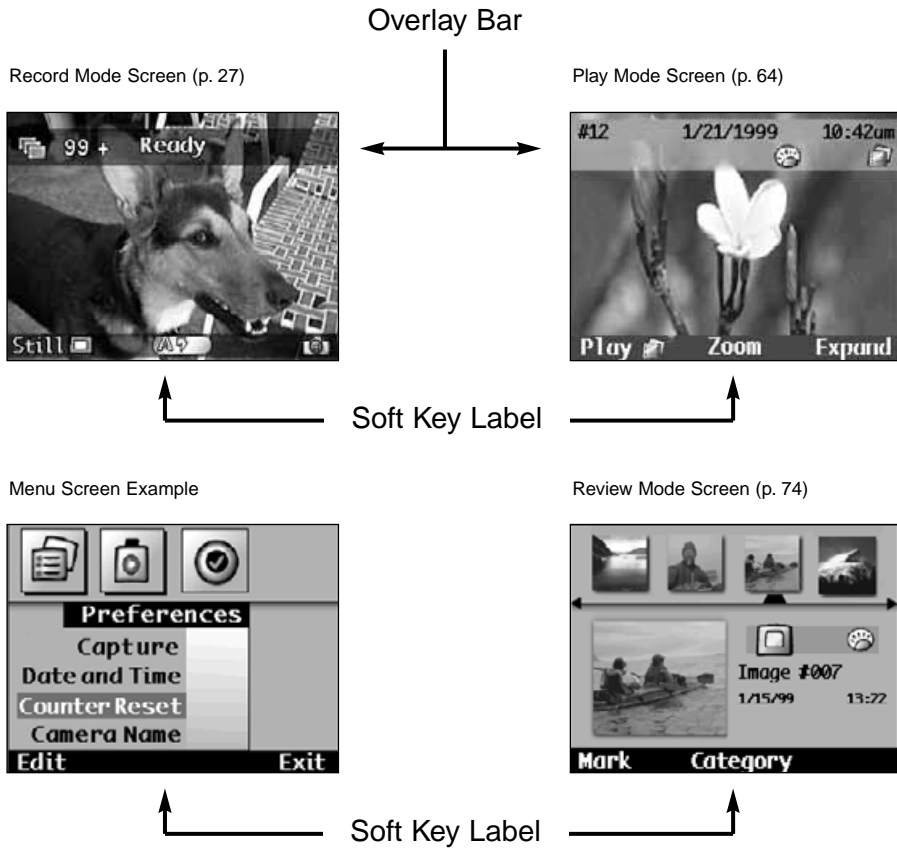

BEFORE RECORDING

VIEWFINDER

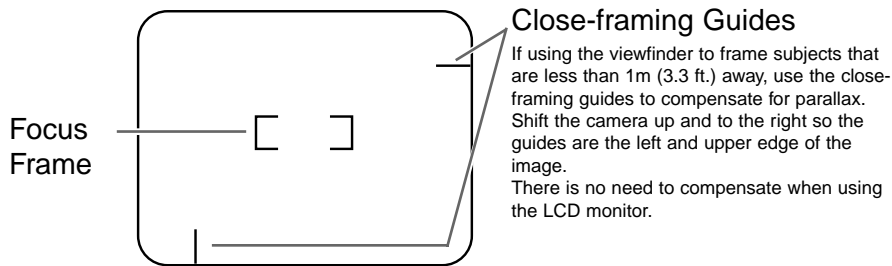

ATTACHING THE STRAP

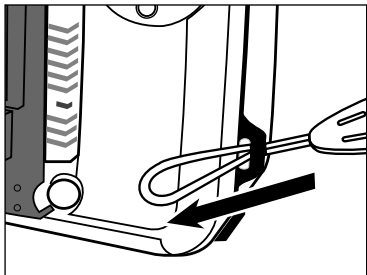

- 1** Insert the smaller loop of the strap through the strap eyelet.

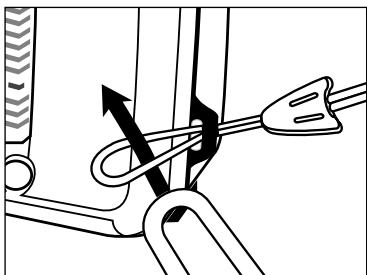

- 2** Put the other end of the strap through the small loop.

INSERTING THE BATTERIES

Your camera uses four AA-size alkaline batteries. Four AA-size Ni-Cd, Ni-MH, or lithium batteries can also be used.

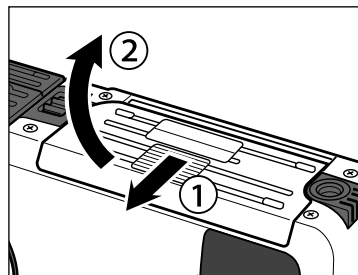

- 1** Open the battery-chamber cover by sliding it in the direction indicated, then open the cover.

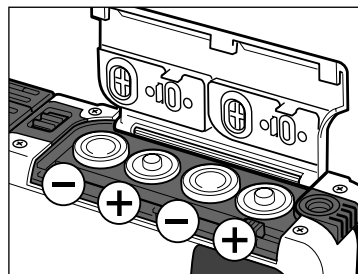

- 2** Insert the batteries as indicated by the +/- diagram.

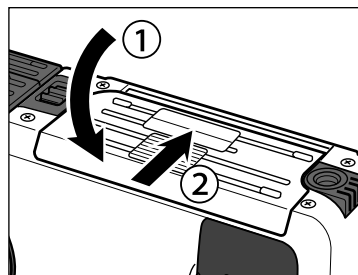

- 3** Close the battery chamber-door and slide it shut until it clicks.

 **CONSERVING BATTERY POWER:** Reduce battery consumption by turning off the LCD monitor when not needed (p. 23). Use the camera's optical viewfinder to frame shots when taking pictures.

LOW-BATTERY INDICATOR



A warning message will appear in the top overlay bar when the battery power is low.

Replace all 4 batteries or use the AC adapter (sold separately).

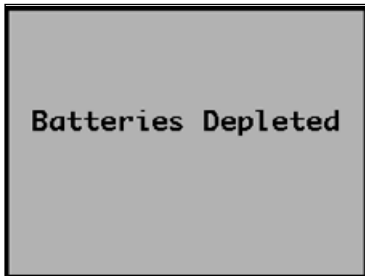

When the battery power is too low for camera operations, an alert dialog will appear on the LCD monitor, then the camera will shut down.

AUTO POWER OFF

The LCD monitor will shut off if the camera has not been used for 3 minutes.

- The power lamp will remain on.
- Press the Display button to turn the LCD monitor back on.

After an additional 3 minutes without use (6 minutes total), the camera will shut down completely.

- The power lamp will turn off.
- Press the main switch to turn the camera back on.

Auto Power Off does not function when the camera is connected to the AC adapter.

This camera records the date and time an image was captured. For your reference, set the date and time for accuracy.

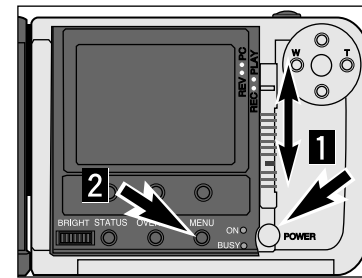

1 Turn the camera on, then slide the mode switch to REC.

2 Press the menu button.

- The menu screen for record mode will appear.

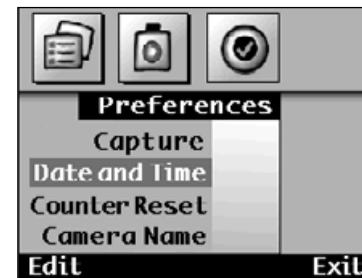

3 Press the Right button until the Preferences menu appears.

Press the Down button until Date & Time is highlighted.

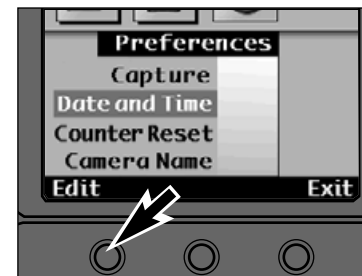

4 Press the Edit soft key .

- The Set Date and Time screen will appear.

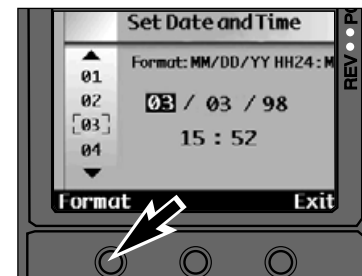

5 Press the Format soft key.

- The Format screen will appear.
- Skip to step 8 if the format does not need to be changed.

SETTING THE DATE AND TIME

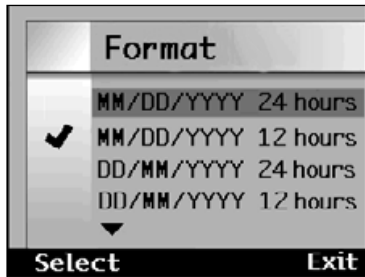

6 Use the up and down buttons to highlight the desired format.

- The currently selected format has a ✓ next to it.

7 Press the Select soft key to select the highlighted format.

- The Set Time & Date screen will appear.

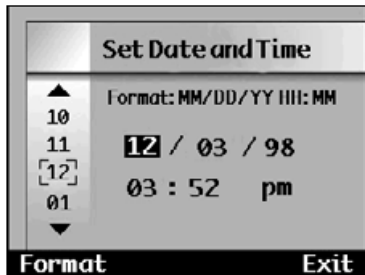

8 Press the Up or Down buttons to select a number.

- The number under the cursor will change.

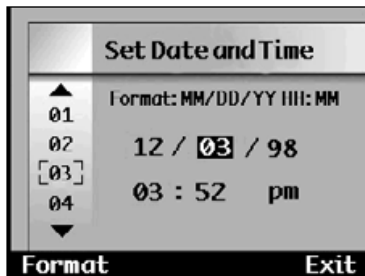

9 Press the Right button to set the item and move to the next item.

- Pressing the Left button will delete the current item and return to the previous item.

10 Repeat steps 8 and 9 until all the items are correct.

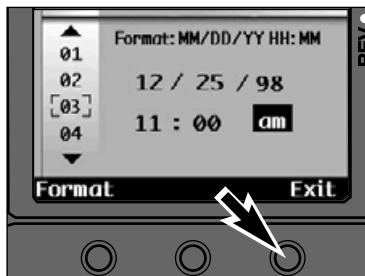

11 Press the Exit soft key.

- Pressing Exit saves the entered data and returns the screen to the Preferences menu. Press Exit in the Preferences menu to return to the Record screen.

COMPACT FLASH CARD

Your camera requires a CompactFlash card to be inserted before capturing images.

INSERTING THE COMPACT FLASH CARD

Always turn off the camera before inserting a CompactFlash card! Data on the card will be lost or damaged if it is inserted while the camera is on.

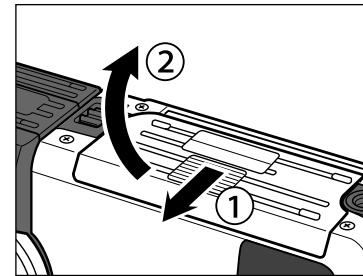

1 Turn the camera off.

2 Open the card-chamber cover by sliding it in the direction indicated, then open the cover.

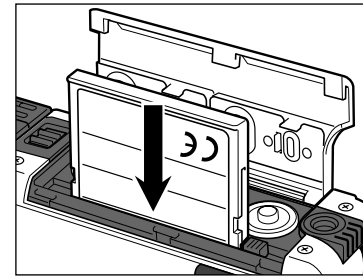

3 Insert the CompactFlash card into the card slot, pushing it in until the card-release lever pops out.

- Insert the card so the back label is on the lens side of the camera.
- Push the card in straight, not at an angle.
- Wrong direction: If the card stops mid-way, confirm the direction of the card. Do not force the card.

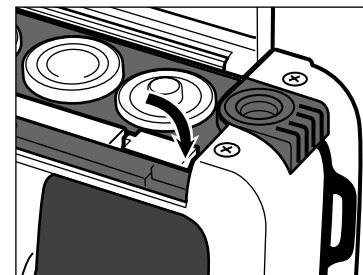

4 Fold the card-release lever down as shown.

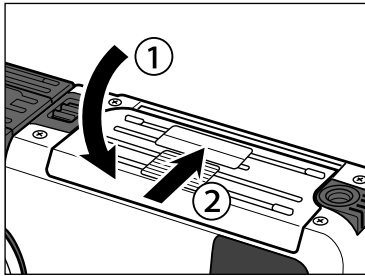

- 5** Close the card-chamber cover and slide it shut until it clicks.

REMOVING THE COMPACT FLASH CARD

Always turn off the camera before removing a CompactFlash card! Data on the card will be lost or damaged if it is inserted while the camera is on. Check the on LED is off before removing the card.

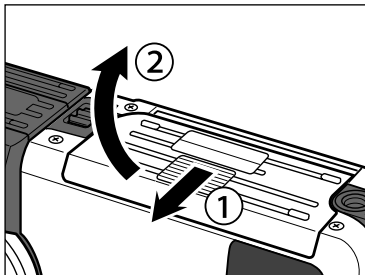

- 1** Turn the camera off.
- 2** Open the card-chamber cover by sliding it in the direction indicated, then open the cover.

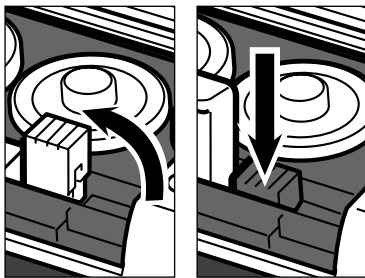

- 3** Lift the card-release lever until it is straight out, then press the card-release lever to eject the card.

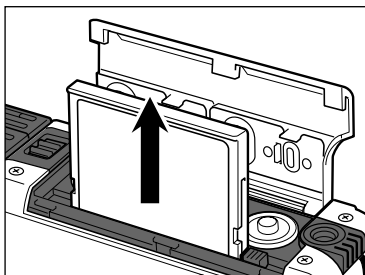

- 4** Pull the memory card straight out.
- Close the card-chamber cover after removing the card.

TURNING THE LCD MONITOR ON/OFF

Reduce battery consumption by turning off the LCD monitor when not needed.

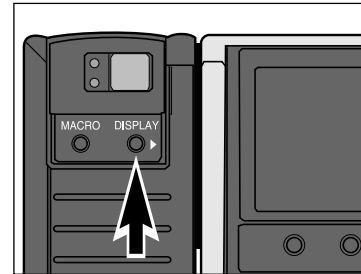

Press the Display button to turn the LCD monitor on or off.

- The camera's power must be on to turn on the LCD monitor.

ADJUSTING THE LCD BRIGHTNESS

The LCD monitor brightness can be adjusted to compensate for varying lighting conditions and viewing angles.

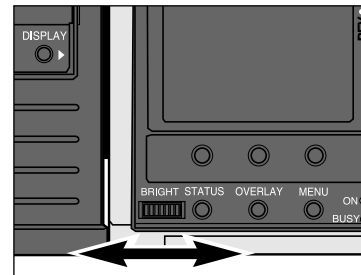

Turn the Brightness-control dial left or right until the desired brightness level is reached.

- Adjusting the brightness of the LCD monitor will not affect the image exposure.

OVERLAY BUTTON

The Overlay button shows or hides the overlay bar and soft key label in each mode, enabling an unobstructed view of the image.

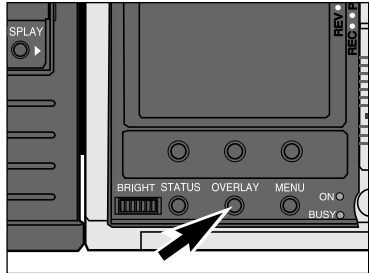

Press the Overlay button on the camera.

- The overlay bar and soft key label will turn on or off for each mode as listed below.

REC (overlay bar/soft key label) ON/ON → OFF/OFF → OFF/ON

PLAY (overlay bar/soft key label) ON/ON → OFF/OFF → OFF/ON

REV (soft key label only) ON ↔ OFF

Pressing any soft key while the label is off will turn the label on.

STATUS BUTTON

The Status screen quickly gives a display of camera status information when the camera is in Record mode.

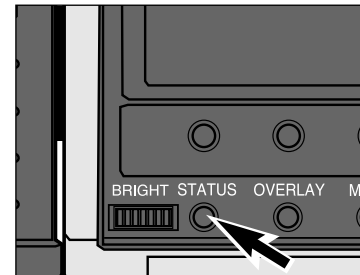

In Record mode, press the Status button on the camera.

- The Status screen will be displayed.
- The displayed items cannot be changed within the Status screen. The displayed items can only be changed through their respective menus.

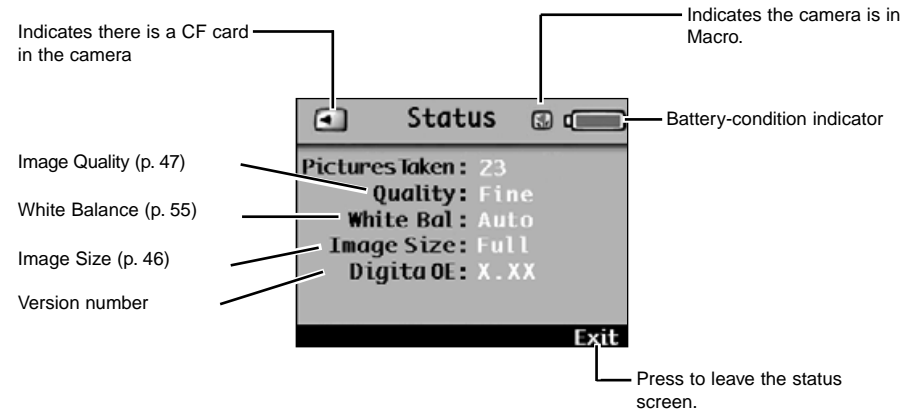

Press the status button a second time to exit the status screen or press the Exit soft key.

Once batteries and a CompactFlash card have been inserted into the camera, it is ready to take pictures. When the camera is turned on, the flash will be set to autoflash and the image capture type will be Still (normal).

Record Mode Screen

RECORD MODE



Approximate number of images remaining: 99 +

Ready



Still

Flash mode

Digital Subject Program Mode

Indicates if camera is ready or busy

Image capture type

- Still 
- Burst 
- Timelapse 

RECORD

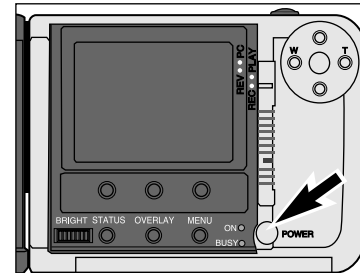

- 1 Press the main switch to turn the camera on.**
 - The Digita™ logo will briefly appear in the LCD monitor.

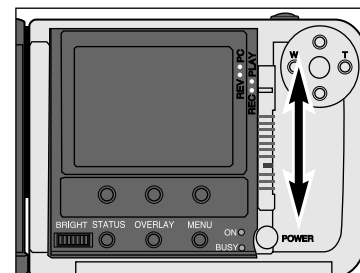

- 2 Slide the Mode switch to REC to put the camera in record mode.**

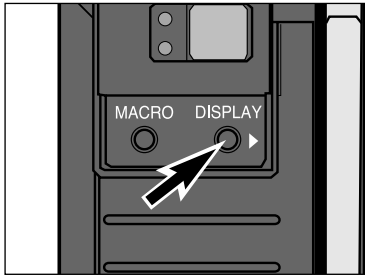

- 3 Press the Display button to turn on the LCD monitor if desired.**
- The LCD monitor's Live View feature will continuously update and display what the lens sees.

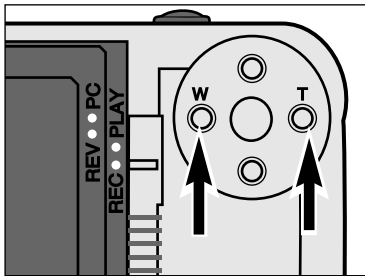

- 4 ZOOM 1500: Press the Left button (W - wide) or the Right button (T - telephoto) until the image is zoomed as desired in the LCD monitor or Viewfinder.**

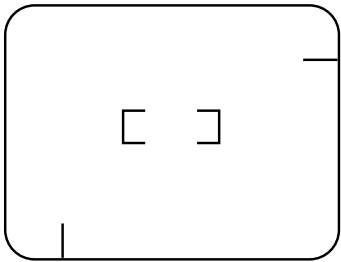

- 5 Center the subject in the LCD monitor or place the viewfinder's focus frame on the subject.**
- Use Focus Hold for off-center subjects (p. 37).

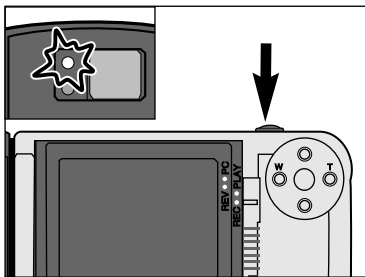

- 6 Press the shutter-release button part way down.**
- Focus and exposure will be determined and locked.
 - The green focus lamp will glow if focus is determined. Repeat steps 5 and 6 if the focus lamp blinks.
 - The orange flash lamp will glow if the flash is charged and ready.

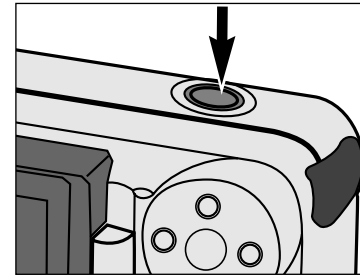

- 7 Press the shutter-release button the rest of the way down to take the picture.**
- Instant Review OFF: The captured image will appear in the LCD monitor only for as long as it takes to write it to the memory card. The camera will return to Live View.
 - The default Instant Review setting is ON. See page 58 to turn instant review off.



Instant Review ON: The captured image will appear in the LCD monitor and **Save** and **Delete** will appear in the soft key label.

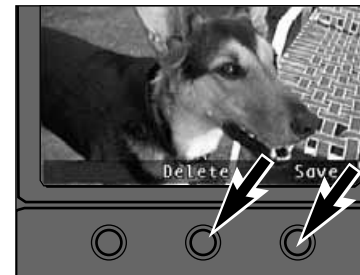

- 8 Press either the Save or Delete soft key.**

The image will be saved automatically after 10 seconds if neither button is pressed. The image will be saved if the shutter-release button is pressed part way down.

If Save is pressed:

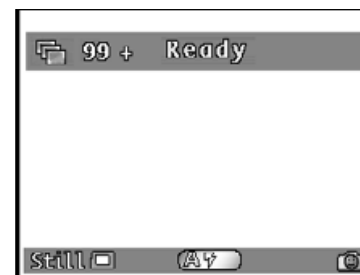

- The image will be saved and the camera will return to Live View.

If Delete is pressed:



- A message appears asking to confirm deletion. The Yes and Cancel soft keys will appear.

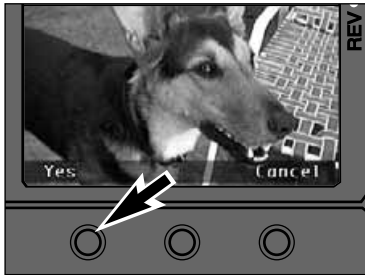

Press the Yes soft key.

- The image is deleted and the camera will return to Live View.
- The Cancel soft key will return the camera to the Record screen without deleting the image.
- The image will be saved automatically after a few seconds if neither button is pressed.

Burst image capture is similar to the motor drive or continuous-drive mode on conventional cameras. The camera will continuously take pictures while the shutter-release button is held down. Up to 7 full-size images and 15 1/4 size images can be captured in one burst at a rate as fast as 3.5 frames/second. See page 52 to select the burst capture rate. Images captured together in one Burst are linked together and treated as a series by the camera when in Play and Review modes.

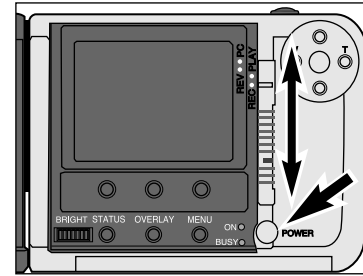

- 1 Turn the camera on and slide the Mode switch to REC.

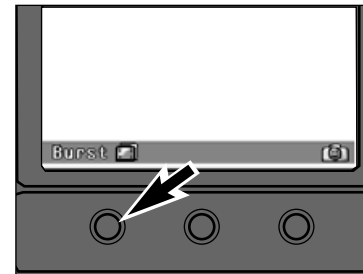

- 2 Press the left soft key until Burst  appears in the soft key label.
 - The image capture modes are displayed in the following sequence.

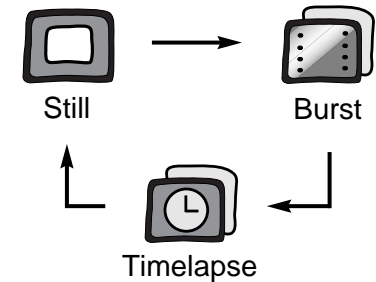

- 3 Frame the picture as instructed in "Taking Pictures", steps 4 through 6.
 - The flash does not operate in Burst. The flash icon over the center soft key will disappear.

BURST IMAGE CAPTURE

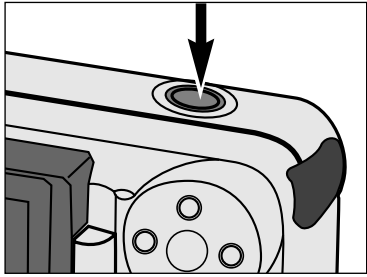

4 Press and hold the shutter-release button all the way down.

- The shutter will continuously release until your finger is lifted from the shutter-release button, the memory buffers become full, or the maximum number of images has been captured.
 - The focus and exposure for the series is determined when the shutter-release button is pressed part-way down before the pictures are taken.
- If the memory buffers are full when the shutter-release button is pressed, **Please wait...** will appear in the overlay bar.

If Instant Review is OFF:

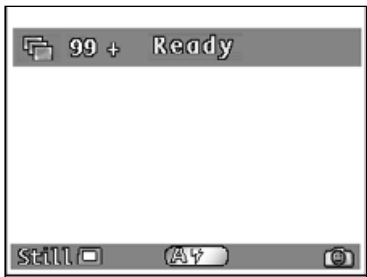

5 Lift your finger from the shutter-release button.

- The last image will appear on the LCD monitor while the series is being written to memory. Once the images are saved, the camera will return to Live View.

If Instant Review is ON:



5 Lift your finger from the shutter-release button.

- The last image will appear on the LCD monitor and **Save** and **Delete** will appear in the soft key label.

6 Press the Save or Delete soft key as instructed in "Taking Pictures".

- The entire series will be saved or deleted.

TIMELAPSE

In Timelapse image capture, the camera will take a series of pictures at regular time intervals. This feature is useful for capturing events over time, such as the opening of a flower. Images captured together in Timelapse are linked together and treated as a series by the camera when in Play and Review modes.

The default settings for Timelapse capturing are:

Timelapse interval: 60 seconds.

Number of Images: 10 images.

See page 53 to change these settings. The interval can be selected from 60 seconds to up to 546 minutes. As many as 200 images can be captured in one Timelapse series.

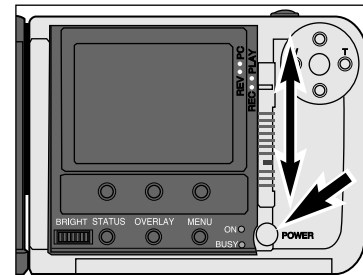

1 Turn the camera on and slide the Mode switch to REC.

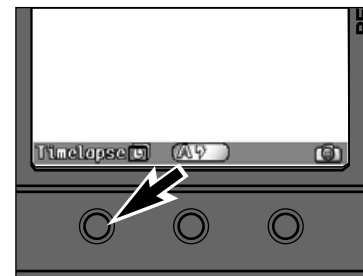

2 Press the left soft key until Timelapse appears in the soft key label.

- The image capture modes are displayed in the following sequence.

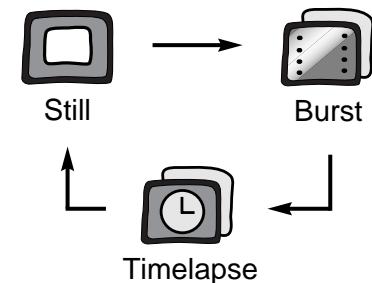

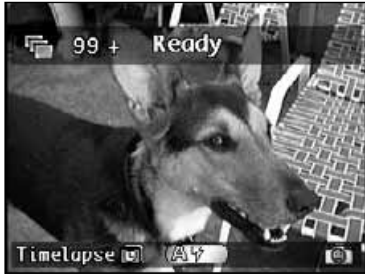

3 Frame the picture as instructed in “Taking Pictures”, steps 4 through 6.

- Place the camera on a tripod or steady surface if necessary.

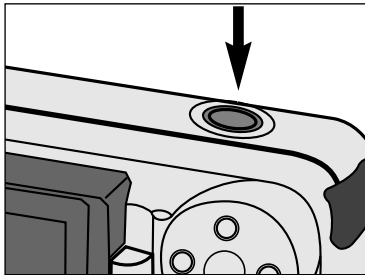

4 Press the shutter-release button all the way down once.

- The first image will be captured immediately, then the other images will be automatically captured at the time interval. The camera will continue to capture images until the Stop soft key is pressed or the pre-determined number of images is reached.
- The focus and exposure is determined for each image just before the each picture is taken.



During the interval:

- A countdown of the time remaining until the next picture is taken appears in the overlay bar.
- The number of images already taken in this Timelapse series appears in the overlay bar.
- Live View remains active.

If Instant Review is OFF:

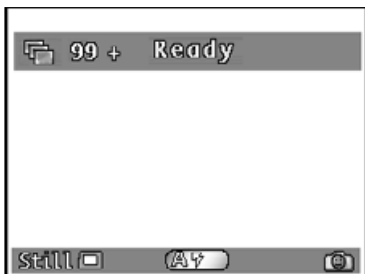

After the Timelapse series is complete, the camera will return to Live View.

If Instant Review is ON:



After the Timelapse series is complete, the last image will appear on the LCD monitor and **Save** and **Delete** will appear in the soft key label.

5 Press the **Save** or **Delete** soft key as instructed in “Taking Pictures”.

- The entire Timelapse series will be saved or deleted.

🔌 Auto Power Off does not operate during Timelapse sequences.

The Zoom 1500 and Wide 1500 lens units have a precise, high-speed autofocus system, just like those found in quality compact cameras.

FOCUS LAMP/NO FOCUS INDICATOR

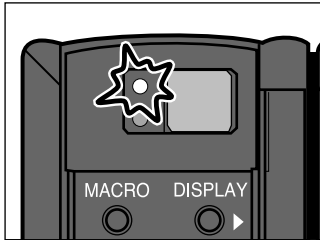

When the shutter-release button is pressed partway down, the autofocus system locks focus at the subject distance. The focus lamp will indicate the focus status when the shutter-release button is pressed partway down.

| | |
|--------|---|
| Glows | Focus is OK and confirmed. |
| Blinks | The subject is too close (see Focus Range below). |
| | One of the Special Focusing Situations applies (p. 37). |

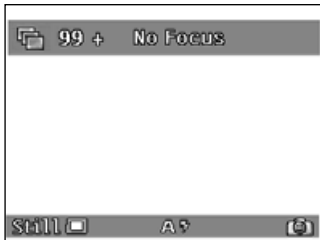

The lens will lock focus at 2.5m (8.2 ft.), the focus lamp will blink, and NO FOCUS will appear in the LCD monitor if the camera cannot confirm focus because the subject is in one of the special focusing situations listed on the following page.

FOCUS RANGE

The green focus lamp will blink **Out of Range** appears in LCD monitor if your subject is closer than the minimum focus distance.

| | |
|-----------|---------------------------------------|
| Wide 1500 | 0.3m - ∞ (0.98 ft. - ∞) |
| Zoom 1500 | 0.5m - ∞ (1.64 ft. - ∞) |
| | MACRO; 0.35m - 0.5m (1.15 - 1.64 ft.) |

SPECIAL FOCUSING SITUATIONS

Some scenes or subjects are difficult for the autofocus system to lock on to. When the focus will not lock, FOCUS HOLD on another object the same distance from you as your main subject, recompose, then press the shutter-release button all-the-way down to take the picture.

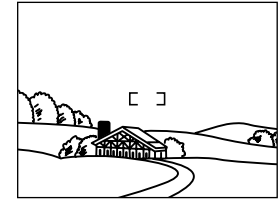

Very bright or low contrast fills the focus frame.

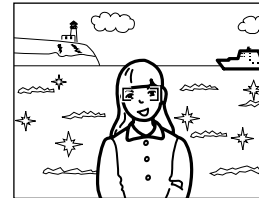

Subject is near very bright object or area.

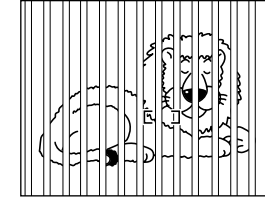

Two subjects overlap in the focus frame.

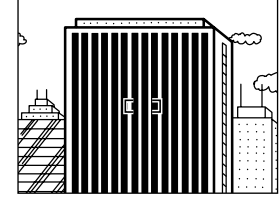

Alternating light and dark lines fill the focus frame.

FOCUS HOLD

Subjects outside the focus frame or LCD monitor center may not be in focus. Use focus hold to ensure accurate focusing.

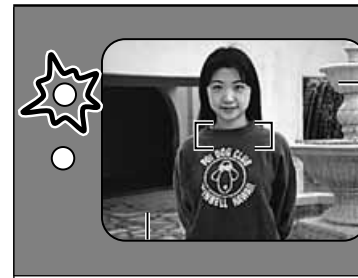





- 1 Place the focus frame on your subject or center the subject in the LCD monitor, then press and hold the shutter-release button partway down so the green focus lamp glows.



- 2 Without lifting your finger, recompose the picture, then press the shutter-release button all-the-way down to take the picture.

BUILT-IN FLASH

When the camera is turned on, the flash is automatically set to autoflash. The other flash modes can be set by using the center soft key.

| | | |
|---|--|--|
|  | AUTOFLASH | In autoflash, the flash will fire automatically when the light level is low or your subject is backlit. |
|  | FILL-FLASH | The flash will fire every time a picture is taken, regardless of lighting. Use fill flash to reduce harsh shadows on your subject's face. |
|  | FLASH CANCEL | Use flash cancel when photographing subjects that are beyond the flash range or when flash photography is prohibited. |
|  | AUTOFLASH WITH RED-EYE REDUCTION | Use the red-eye reduction feature to reduce the red-eye effect when photographing people or animals in low light situations. The flash will fire a few short bursts before the main flash burst. Use of a tripod is recommended. |
|  | FILL-FLASH WITH RED-EYE REDUCTION | |

CHANGING THE FLASH MODE

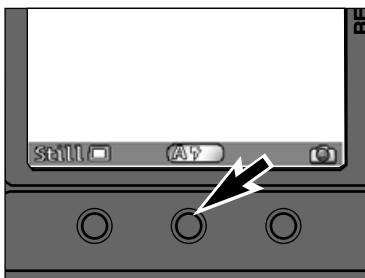

Press the center soft key until the desired flash mode is displayed.

- The flash modes will change as follows:

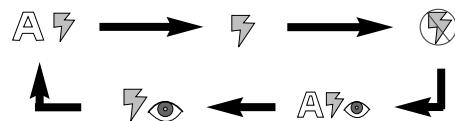

- The flash cannot be used in Burst capture mode.
- The selected flash mode remains until the camera is turned off or another flash mode is selected.

BUILT-IN FLASH

FLASH RANGE

To ensure proper exposure, make sure your subject is positioned within the flash range. The flash range for the Zoom 1500 lens unit changes with focal length being used.

| | | |
|-----------|----------------|-------------------------------|
| Zoom 1500 | wide (7 mm)* | 0.5 - 3.5m (1.64 - 11.48 ft.) |
| | tele (21 mm)** | 0.5 - 2.3m (1.64 - 7.54 ft.) |
| Wide 1500 | — | 0.3 - 6.7m (0.98 - 21.98 ft.) |

* 35mm equivalent 38mm

** 35mm equivalent 115mm

SHAKE WARNING



When FLASH CANCEL is selected and the light level is too low for a sharp picture while hand-holding the camera, **Shake Warning** will appear on the overlay bar. Use a tripod or select AUTOFLASH.

FLASH LAMP

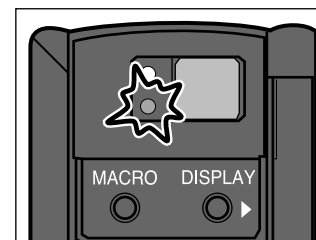







The orange flash lamp will indicate the flash status when the shutter-release button is pressed partway down.

Glow: Flash is charged and ready.

Blinks: The flash is charging.

The Digital Scene Selector sets the optimum flash mode, light metering, white balance, and image processing for specific scene types. When the camera is turned on, the scene selection mode is set to Auto.

| | | |
|---|----------------------------|--|
|  | AUTO | This is the default setting. No additional image processing is performed in this mode. |
|  | PORTRAIT | The Portrait selection reduces noise and softens edges. As named, this setting is best suited for portraiture. |
|  | LANDSCAPE | The Landscape setting is ideal when shooting nature subjects or architecture. By sharpening the image, the camera faithfully reproduces fine textures. |
|  | EVENING/ SUNSET | The white balance is automatically adjusted for the scene, making it possible to capture the natural warm tones of the setting sun. |
|  | NIGHT SCENE | Digital noise reduction is used to allow crisper clearer images to be captured at night. |
|  | SLOW-SYNC | In this mode a slower shutter speed, as low as 2 seconds, with rear-flash sync is used and noise is reduced. This allows ambient light in the background to appear in the picture. Use of a tripod is recommended. |

CHANGING THE DIGITAL SCENE SELECTOR MODE

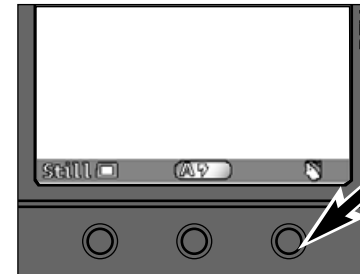

Press the right soft key until the icon for the desired mode appears.

- The modes will change as follows:

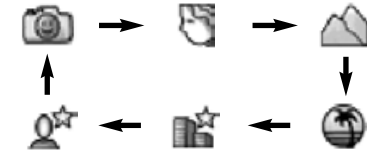

- The scene selection mode remains until the camera is turned off or another scene selection mode is chosen.

MACRO (ZOOM 1500 LENS ONLY)

The Macro Photography function on the Zoom 1500 lens allows you to fill the frame with a business-card size object. The minimum focus distance in Macro is 0.35m (1.15 ft.).

- Autofocus does not operate when the lens is in Macro, manual focus must be used.

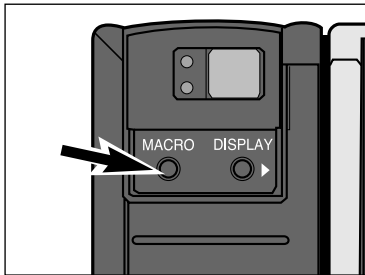

1 Press the Macro button.

- The Focus Aid Meter will appear, replacing the image counter.
- Autofocus will be disabled and manual focus will become available.

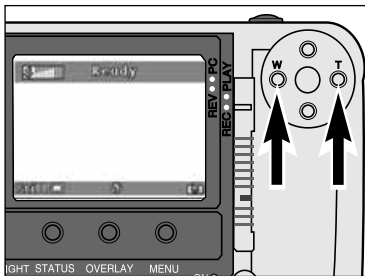

2 Frame the image, then press the Left or Right button to focus.

- The Focus Aid Meter displays 10 levels of focus. Manually focus the lens by pressing the Left or Right button until the focus meter is as close to maximum as possible.



Minimum focus level

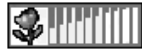

Maximum focus level

- For best results, steady the camera on a stable surface or use a tripod.

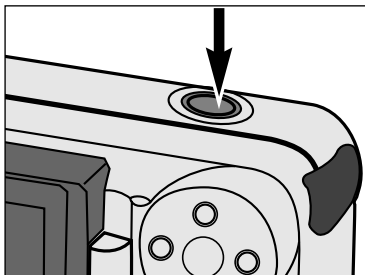

3 Press the shutter-release button to take the picture.

- The focus range in Macro is from approximately 0.35m - 0.5m (1.15 - 1.64 ft.).
- The Macro focus range is outside of the flash range, turn the flash off (Flash Cancel).

EXPOSURE COMPENSATION

The exposure can be adjusted to make the final image lighter or darker. Exposure can be adjusted as much as +/- 2 EVs in 1/3 EV increments.

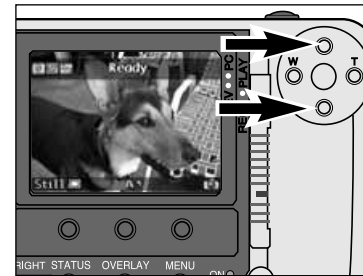

1 While in Record mode, press the Up or Down button to select the exposure compensation value.

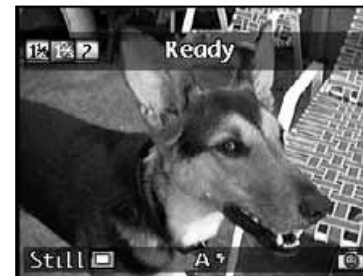

- The exposure compensation values are displayed in the upper-left corner of the LCD monitor, replacing the image counter.
- The exposure can be biased as much as +/-2 EVs in 1/3EV increments.
- The exposure change is visible in the LCD monitor.

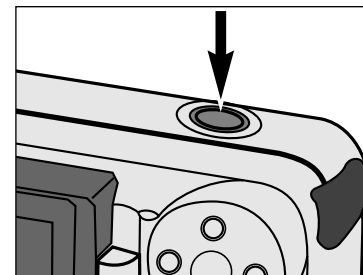

2 Frame the image, then press the shutter-release button.

- The exposure compensation value remains active after the picture is taken.

- Exposure can only be adjusted in Record mode. Set the exposure compensation before recording the image. Once the image is captured, it cannot be changed in the camera.
- Reset the exposure compensation value to 0 when finished. The exposure compensation values do not remain in the overlay bar, but the exposure compensation value remains active.

The Record Mode menus allow you to change the default settings for image capturing, like Image Size and Image Quality settings. They also give additional function options for more advanced operation, such as using the self-timer or bracketing.

RECORD MODE MENUS

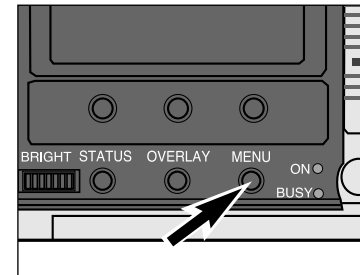

1 Turn the camera on and slide the mode switch to REC.

2 Press the menu button.

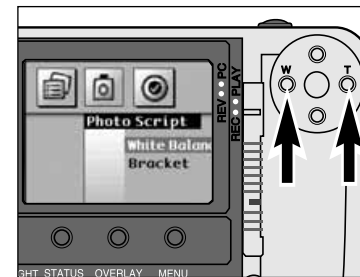

3 Press the Left or Right button until the desired menu appears.

- There are three menu options:
 - Media Settings
 - Photo Script
 - Preferences
- A fourth menu option, Custom Script, is available if additional scripts have been added to the camera (p. 102).

RECORD MODE MENUS

Media Settings:

Still
Size
Quality
Colour
Burst
Size
Quality
Colour
Timelapse
Size
Quality
Colour
Interval
of Images

Photo Script:

White Balance
Auto
Daylight
Tungsten
Fluorescent
Bracket
Off
Half Stop
Full Stop

Preferences:

Capture
File Type
Instant Review
System Sounds
Date and Time
Counter Reset
Camera Name
Format Card

SELECTING THE IMAGE SIZE

Select the image size before recording the image. The image size is a factor in determining how many images fit onto a CompactFlash card (pp. 104 – 105). There are two image size options; **Full (1344 x 1008 pixels)** and **1/4 (640 x 480 pixels)**.

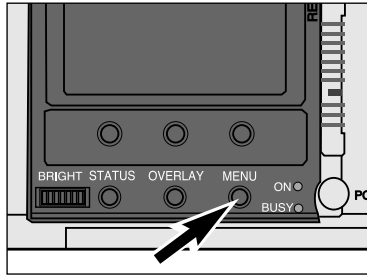

1 In Record mode, press the Menu button.

- The Record mode menus will appear.



2 Press the Left or Right button to highlight Media Settings.

Press the Up or Down button to highlight desired image type; Still, Burst, or Timelapse.

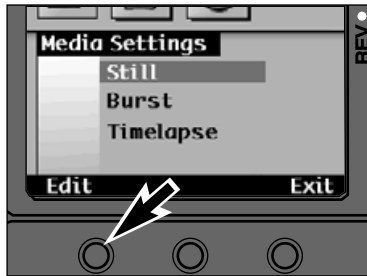

3 Press the Edit soft key.

- The appropriate Settings menu will appear. The menu will vary slightly between image capture types.

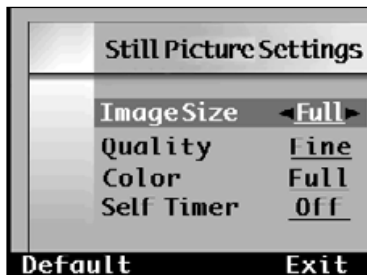

4 Press the Up or Down button to highlight Image Size.

Press the Left or Right button to select either Full or 1/4.

5 Press the Exit soft key.

- The Default soft key will return all the settings on the screen to their default setting.

SELECTING IMAGE QUALITY

Image quality is determined by how much the image is compressed. Little or no compression means high image quality, but large file sizes. High compression ratios mean small file sizes, but lower image quality. The image quality is a factor in determining how many images fit onto a CompactFlash card (pp. 104 – 105). Select the image quality before recording the image. There are four options for image quality:

Super Fine (1:1 compression ratio)

Fine (1:8 compression ratio)

Standard (1:20 compression ratio)

Economy (1:40 compression ratio)

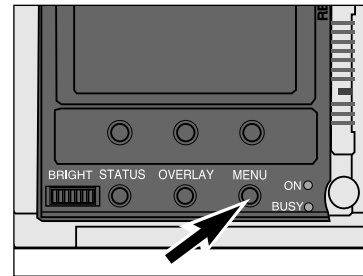

1 In Record mode, press the Menu button.

- The Record mode menus will appear.



2 Press the Left or Right button to highlight Media Settings.

Press the Up or Down button to highlight desired image type; Still, Burst, or Timelapse.

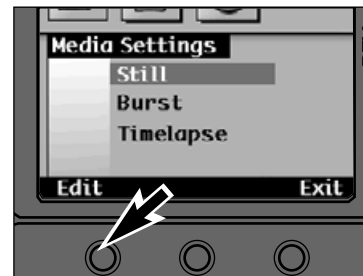

3 Press the Edit soft key.

- The appropriate Settings menu will appear. The menu will vary slightly between image capture types.

SELECTING IMAGE QUALITY



- 4** Press the Up or Down button to highlight Quality.

Press the Left or Right button to select either S. FINE (Super Fine), FINE, STD. (Standard), or ECON. (Economy).



- 5** Press the Exit soft key.
- The Default soft key will return all the settings on the screen to their default setting.

SELECTING COLOUR OR B&W

The default setting is colour image capture. It is possible to capture images in black & white only. B&W images use less storage space than full colour images. Consider this option to save space on CompactFlash cards if the final output will be B&W. Select before taking the photograph.

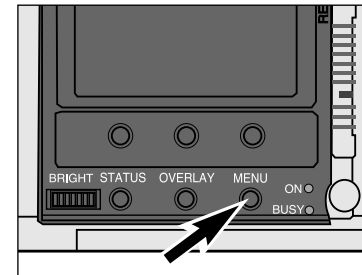

- 1** In Record mode, press the Menu button.
- The Record mode menus will appear.



- 2** Press the Left or Right button to highlight Media Settings.

Press the Up or Down button to highlight desired image type; Still, Burst, or Timelapse.

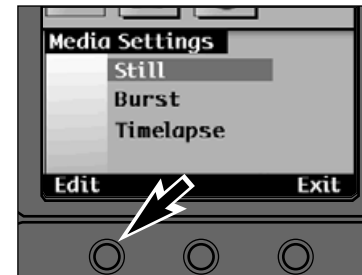

- 3** Press the Edit soft key.
- The appropriate Settings menu will appear. The menu will vary slightly between image capture types.



- 4** Press the Up or Down button to highlight Colour.

Press the Left or Right button to select either Full or B&W.

- 5** Press the Exit soft key.
- The Default soft key will return all the settings on the screen to their default setting.

SELF TIMER

The self-timer delays release of the shutter for approximately 10 seconds after the shutter-release button is pressed.

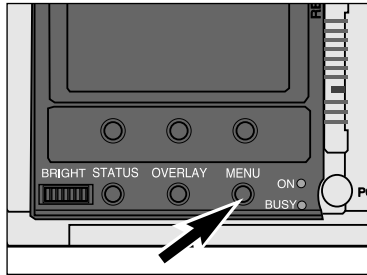

1 In Record mode, press the Menu button.

- The Record mode menu will appear.



2 Press the Left or Right button to highlight Media Settings.

Press the Up or Down button to highlight Still.

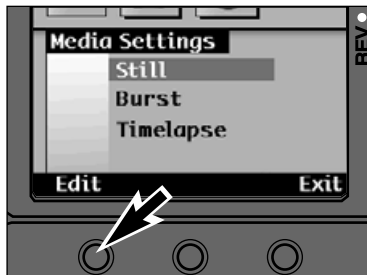

3 Press the Edit soft key.

- The Still Picture Settings menu will appear.

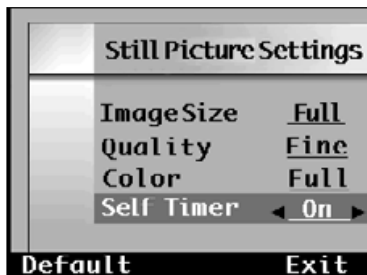

4 Press the Up or Down button to highlight Self Timer.

Press the Left or Right button to select On.

SELF TIMER

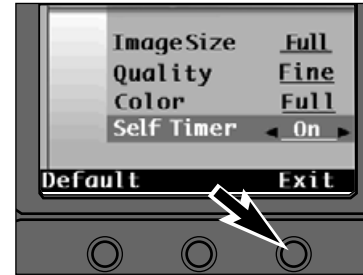

5 Press the Exit soft key.

- The camera will return to the Media Settings menu.
- The Default soft key will return all the settings on the screen to their default setting.

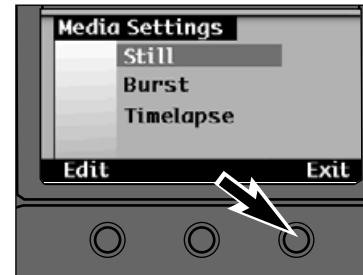

6 Press the Exit soft key in the Media Settings menu.

- The camera will return to the Record screen.

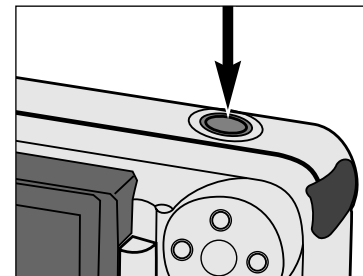

7 Place the camera on a tripod, frame your subject, then press the shutter release button.

- The self-timer lamp on the front of the camera will blink and a countdown will appear in the LCD monitor.
- Do not press the shutter-release button while standing in front of the camera.
- Cancel the countdown by turning the camera off.

The self-timer is automatically cancelled after the picture is taken.

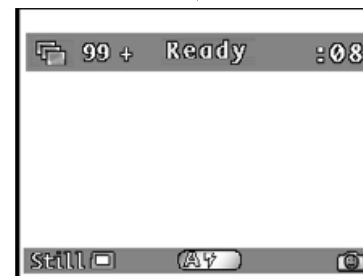

Self-timer is not available for Burst or Timelapse image types.

SELECTING BURST CAPTURE RATE

The speed of the burst capture can be adjusted. There are three burst capture rate options; **Fast** (3.5 frames per second approximately), **Medium** (2.5 fps aprox.), and **Slow** (1.2 fps aprox.).

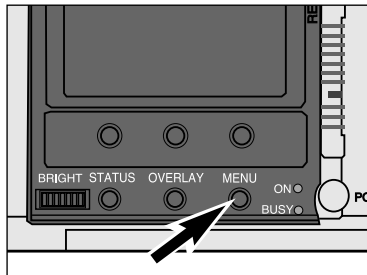

1 In Record mode, press the Menu button.

- The Record mode menus will appear.



2 Press the Left or Right button to highlight Media Settings.

Press the Up or Down button to highlight Burst.

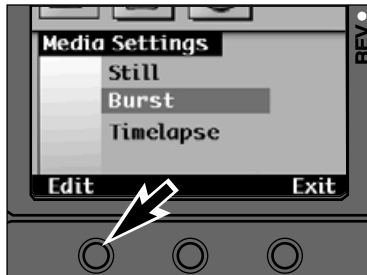

3 Press the Edit soft key.

- The Burst Settings menu will appear.

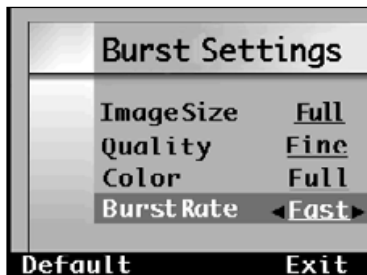

4 Press the Up or Down button to highlight Burst Rate.

Press the Left or Right button to select Fast, Medium, or Slow.

5 Press the Exit soft key.

- The Default soft key will return all the settings on the screen to their default setting.

TIMELAPSE INTERVAL AND TOTAL IMAGES

Select the desired number of images and the amount of time between image captures for Timelapse. The capture options are:

Number of images: 2 - 200

Interval: 60 - 32767 Seconds; 1 - 546 minutes

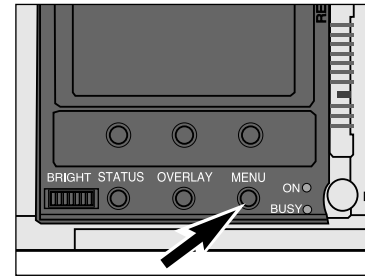

1 In Record mode, press the Menu button.

- The Record mode menus will appear.



2 Press the Left or Right button to highlight Media Settings.

Press the Up or Down button to highlight Timelapse.

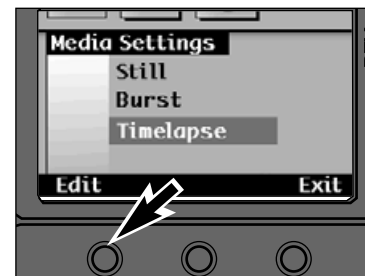

3 Press the Edit soft key.

- The Timelapse Settings menu will appear.

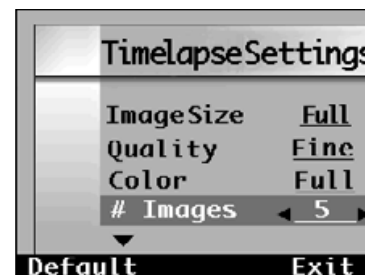

4 Press the Up or Down button to highlight # Images.

Press the Left or Right button to select the desired setting.

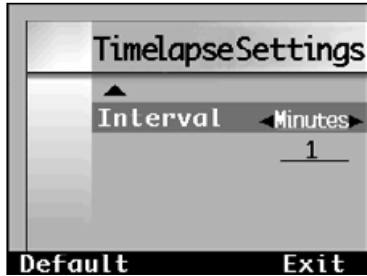

5 Press the Up or Down button to highlight Interval.

Press the Left or Right button to select Seconds or Minutes.

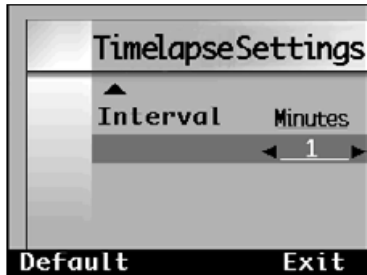

6 Press the Down button to highlight the interval time.

Press the Left or Right button to select the desired setting.

- The interval setting options are:
 - Seconds: 60 - 32767
 - Minutes: 1 - 546

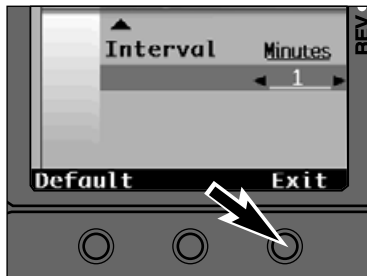

7 Press the Exit soft key.

- The Default soft key will return all the settings on the screen to their default setting.

White Balance is the camera's ability to make different types of lighting appear neutral. The effect is similar to selecting daylight film or tungsten film. The default white balance setting is Auto.

Auto

The Auto setting will detect the type of light and adjust the white balance accordingly.

Daylight

For daylight or camera flash.

Tungsten

For incandescent lighting, such as the filament light bulbs in household lamps.

Fluorescent

For fluorescent lighting.

1 Go to the Photo Script menu (p. 45).

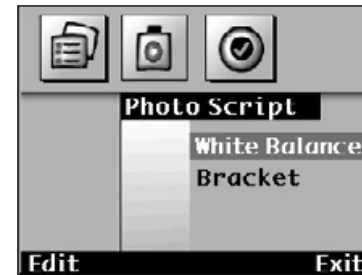

2 Press the Up or Down button until White Balance is highlighted.

3 Press the Edit soft key.

- The White Balance menu will appear.

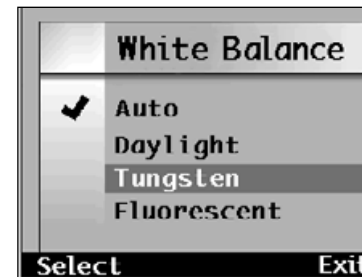

4 Press the Up or Down button to highlight the desired setting.

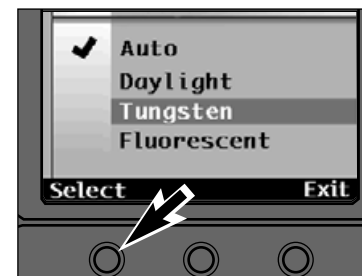

5 Press the Select soft key.

- A check mark will appear next to the selected setting, the white balance setting will be effective, and the camera return to the Photo Script menu.
- Press the Exit soft key to return to the Photo Script menu without changing the white balance setting.

⚙ Set the flash to Flash Cancel when Tungsten or Fluorescent is selected.

BRACKET

The bracketing feature allows you to capture a set of three frames, one with normal exposure, one below normal exposure and one above normal exposure. Select a half stop exposure bracket or a full stop exposure bracket.

1 Go to the Photo Script menu (p. 56).

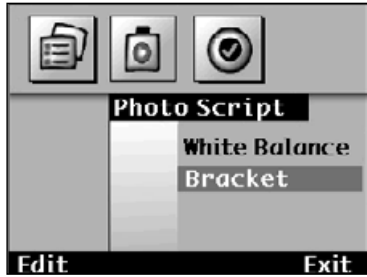

2 Press the Up or Down button until Bracket is highlighted.

3 Press the Edit soft key.

- The Bracket menu will appear.



4 Press the Up or Down button to highlight the desired setting.



5 Press the Select soft key.

- A ✓ mark will appear next to the selected setting and the camera will exit the menu function return to the Record screen.

- Press the Exit soft key to return to the Photo Script menu without changing the setting.



BRACKET

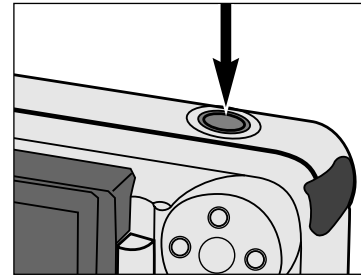

6 Frame your subject, then press and hold the shutter the shutter-release button down.

- The camera will make three exposures. Do not lift your finger from the shutter-release button until all three exposures have been made.
- The camera will return to the Photo Script menu when all three exposures have been made.

Instant Review is the feature that keeps the captured image on the screen, allowing the user to select Save or Delete. When instant review is on, the captured image is also saved by pressing the shutter-release button partway down or by allowing the camera to remain idle for about 10 seconds.

It is possible to turn instant review off. When instant review is off, the captured image will remain on the screen only for as long as it takes to write it to the memory card. There will be no soft key prompts to save or delete captured images, all images will be saved automatically.

1 Go to the Preferences menu (p. 45).



2 Press the Up or Down button until Capture is highlighted.

3 Press the Edit soft key.

- The Capture menu will appear.

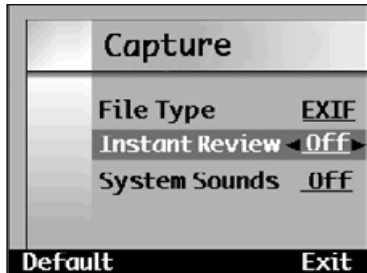

4 Press the Up or Down button until Instant Review is highlighted.

5 Press the Left or Right button to select either On or Off.

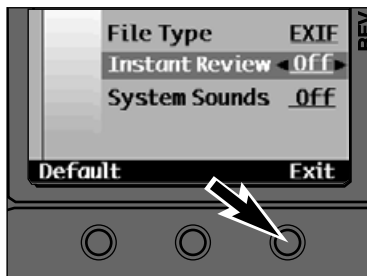

6 Press the Exit soft key.

- The setting will be changed and the camera will return to the Preferences menu. Press the Exit soft key again to return to the Record screen.

- Pressing the Default soft key will return all items in the Capture screen to their default settings. The default settings are:
File Type - EXIF
Instant Review - On
System Sounds - On

Turn the system sounds off or on as desired. The system sounds are the tones heard when certain buttons are pressed.

1 Go to the Preferences menu (p. 45).

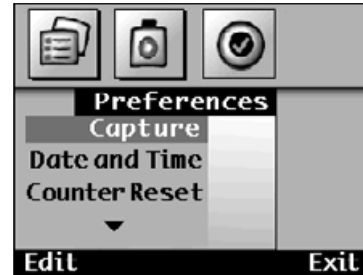

2 Press the Up or Down button until Capture is highlighted.

3 Press the Edit soft key.

- The Capture menu will appear.

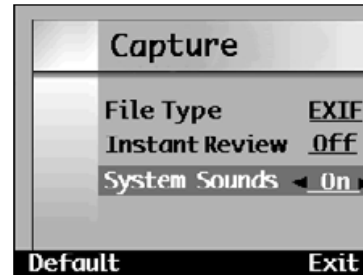

4 Press the Up or Down button until System Sounds is highlighted.

5 Press the Left or Right button to select either On or Off.

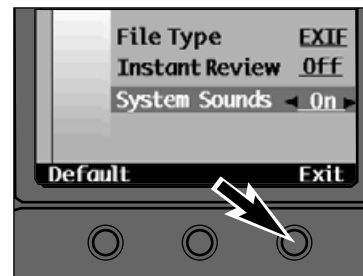

6 Press the Exit soft key.

- The setting will be changed and the camera will return to the Preferences menu. Press the Exit soft key again to return to the Record screen.

- Pressing the Default soft key will return all items in the Capture screen to their default settings. The default settings are:
File Type - EXIF
Instant Review - On
System Sounds - On

COUNTER RESET

The image counter can be set two different ways. The image counter assigns a chronological number to recorded images. This number will appear with the image when viewed in Play mode and Review mode. There are two options for the image counter reset.

Reset When Empty

The counter resets each time a new compact flash card is inserted or all the images on the compact flash card have been deleted.

Capture Counter

This counts each image taken by the camera.

1 Go to the Preferences menu (p. 45).



2 Press the Up or Down button until Counter Reset is highlighted.

3 Press the Edit soft key.

- The Counter Reset menu will appear.

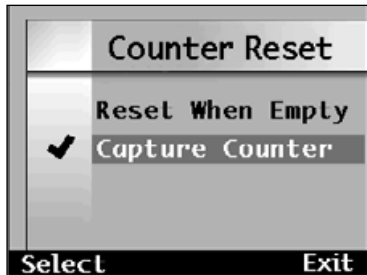

4 Press the Up or Down button to highlight the desired counter type.

- Press the Default soft key to select the default setting of Capture Counter.

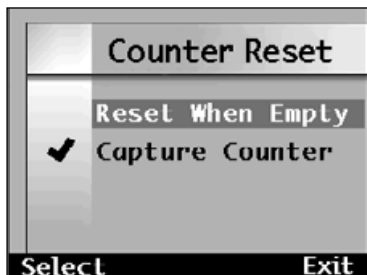

5 Press the Exit soft key.

- A (check) will appear next to the selection, then the camera will return to the Preferences menu. Press the Exit soft key again to return to the Record screen.

CAMERA NAME

The camera name appears at bottom of the Review Screen when viewing images. A total of 31 characters, including numbers, symbols, and spaces, can be entered.

1 Go to the Preferences menu (p. 45).

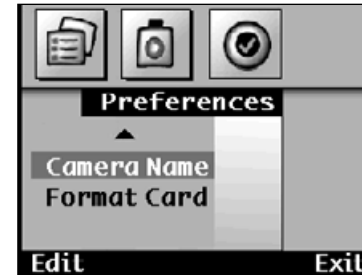

2 Press the Up or Down button until Camera Name is highlighted.

3 Press the Edit soft key.

- The Camera Name menu will appear.

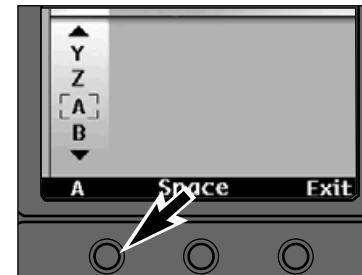

4 Press the left soft key to select capital letters (A), lower-case letters (a), numbers (1), or symbols (%).

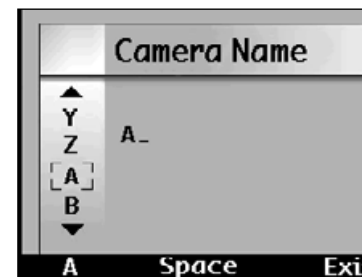

5 Press the Up or Down button to select a character, then press the Right button to set the character and move to the next space.

- Use the Space soft key to insert a blank space into the name.

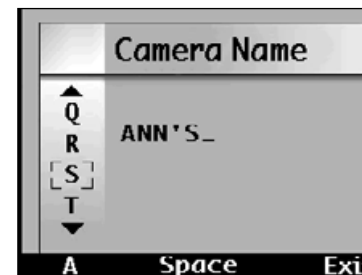

6 When the name is complete, press the Exit soft key.

- The camera will return to the Preferences menu.

FORMATTING COMPACT FLASH CARDS

Formatting the compact flash card removes all the protected and unprotected images on the card. Images cannot be recovered once the card is formatted.

1 Go to the Preferences menu (p. 45).

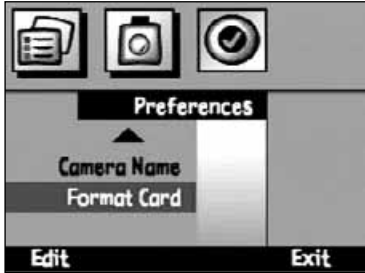

2 Press the Up or Down button until Format Card is highlighted.

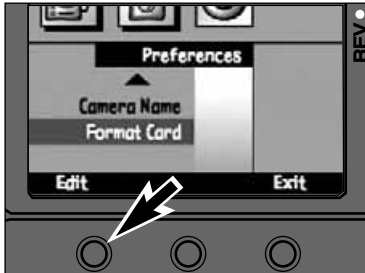

3 Press the Edit soft key.
• A confirmation screen will appear.



4 Press the Start soft key.
• All data on the compact flash card will be deleted and the card will be formatted.

PLAY MODE

The captured images are viewed full screen in Play mode. It is possible to view the images with or without the capture data.

Play Mode Screen

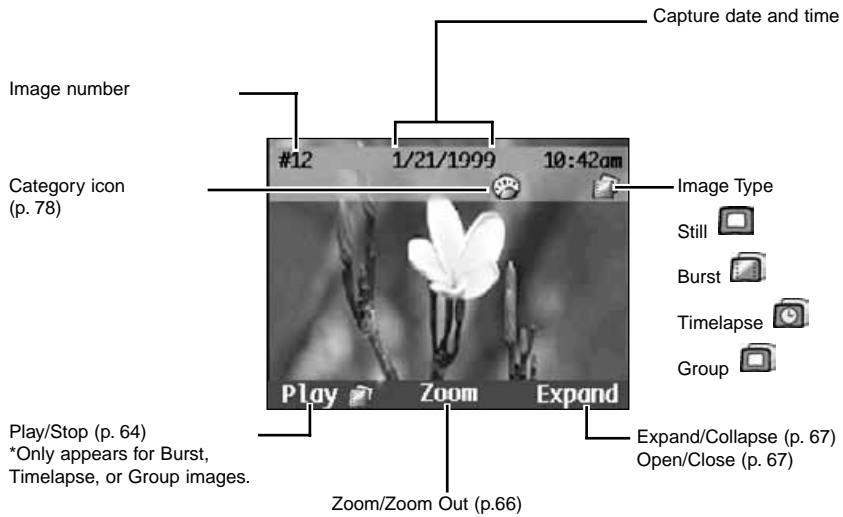

The overlay bar and soft key label can be turned off using the Overlay button, allowing an unobstructed view of the image (p. 24).

Playing Images

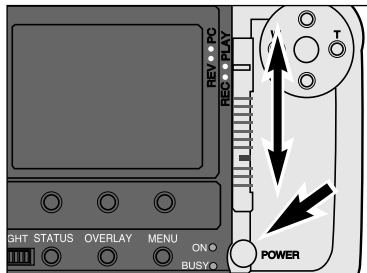

- 1** Turn the camera on.
- 2** Slide the Mode switch to PLAY.

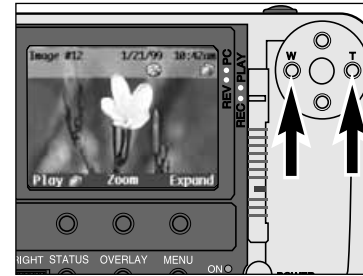

- 3** Press the Right button to display the next image.

Press the Left button to display the previous image.

Press and hold the Left or Right button to continuously scroll through the images.

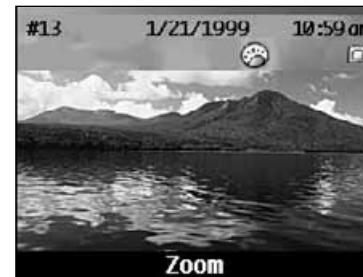

The camera has an internal sensor which detects when images are framed vertically. Vertically framed images will appear correct-side up in the LCD display.

ZOOM IN - ZOOM OUT

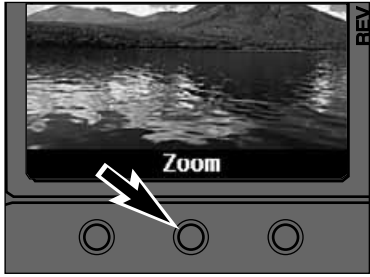

- 1 Press the Zoom soft key to see a magnified view of the image.



- 2 Use the Up, Down, Left, and Right buttons to pan around the image

- 3 Press the Zoom Out soft key.
 - The Zoom Out soft key must be pressed before scrolling to the next image.

EXPAND/COLLAPSE - OPEN/CLOSE

Burst, Timelapse, and Group images are represented by only the first image in the set. It is possible to expand the set so that all the images can be viewed. The Expand and Collapse soft key labels appear for Burst and Timelapse images. The Open and Close soft key labels appear for Grouped images.

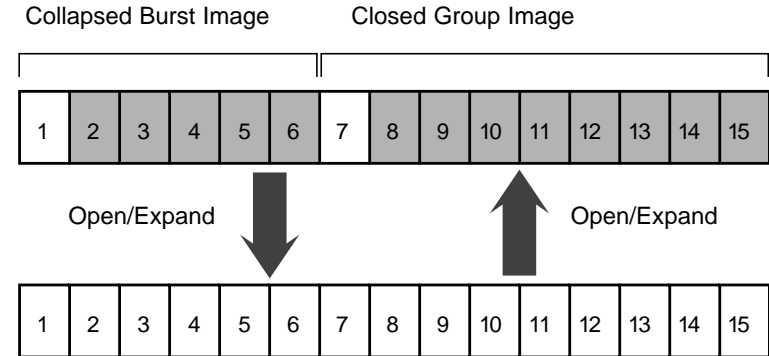

The white blocks represent images that are viewable. The gray blocks represent images that are hidden until the Open or Expand soft key is pressed.



- Press the Expand or Open soft key when the first image in the set is displayed.

- The icon will change to the Still Image icon.



- Press the Collapse or Close soft key when any image in the set is displayed.

If a set has been expanded in Review mode, then Play mode is selected, the set will still be expanded in Play mode.

Burst, Timelapse, and Group images can be played back like an automatic slide show. The Play mode also has a slideshow function that allows more control (p. 70)



1 Scroll through the images until the desired image is on the screen (p. 64).

- The Play soft key is displayed when a Burst, Timelapse, or Group image is on the screen.

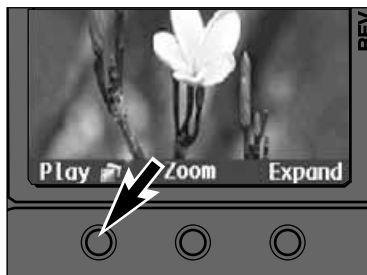

2 Press the Play soft key.

- The Play soft key changes to Stop while playing. Press the Stop soft key to end the playback.

- The default playback rate is 3 seconds per image. See page 72 to change the playback rate.



PLAY MODE MENUS

Create and run a slideshow using the slideshow menu. The slideshow parameter options are:

Content

All images in the camera or the images in a selected category.

Duration

1 - 10 seconds. The length of time each image is displayed.

Loop

On or Off. Whether or not the slideshow continuously repeats play.

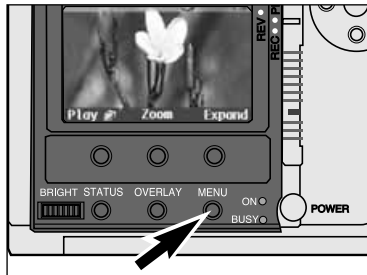

1 Turn the camera on and slide the Mode switch to PLAY.

2 Press the menu button.

- The Play mode menu will appear.



3 Press the Up or Down button to highlight Slide Show.

4 Press the Edit button.

- The Slide Show Preferences screen will appear.

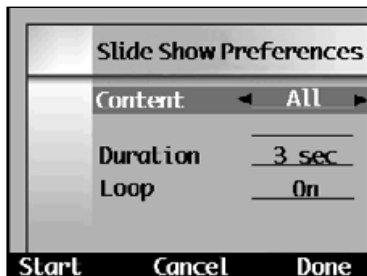

5 Press the Up or Down button to highlight Content, then press the Left or Right button to select either Category or All.

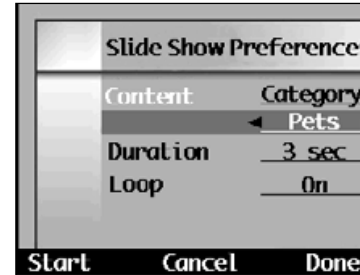

6 If Category is selected: Press the Up or Down button to highlight the category list, then press the Left or Right button to select the desired category.

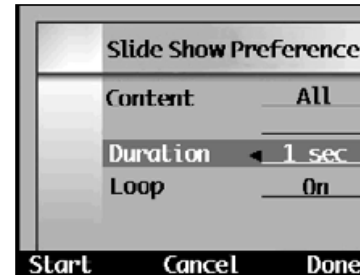

7 Press the Up or Down button to highlight Duration, then press the Left or Right button until the desired duration is displayed.

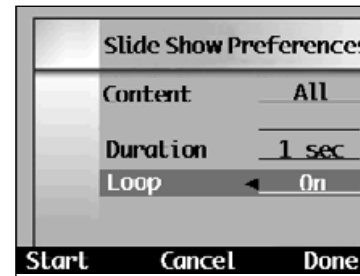

8 Press the Up or Down button to highlight Loop, then press the Left or Right button to select either On or Off.

9 Press the Start soft key.

- The camera will return to the Play mode screen and will begin displaying images according to the above criteria.

- The Cancel soft key returns the camera to the Play Settings menu without changing the settings and without running the slide show. The Done soft key enters the new settings, but returns the camera to the Play Settings menu without running the slide show.



- Stop the slide show by pressing the Stop Slideshow soft key in the Play screen.

PLAYBACK RATE

Set the playback rate for the Play button (p. 68). The playback rate is set for each image type; Burst, Timelapse, and Group. The rate can be selected between 1 and 10 seconds.

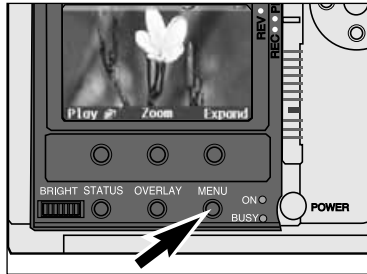

1 In Play mode, press the menu button.

- The Play Settings menu will appear.



2 Press the Up or Down button to highlight Playback Rate, then Press the Edit soft key.

- The Playback Rate screen will appear.



3 Press the Up or Down button to select the image type.

Press the Left or Right button to select the rate.

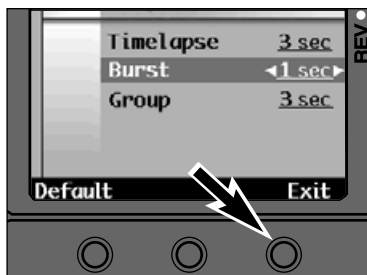

4 Press the Exit soft key.

- The settings will be entered and the camera will return to the Play Settings menu.
- Press the Default soft key to set the rate for all image types to 3 seconds.

REVIEW MODE

Review mode makes it fast and easy to review the images on the compact flash card by displaying mini previews of the images. This mode also allows the images to be categorized or marked.

Review Mode Screen

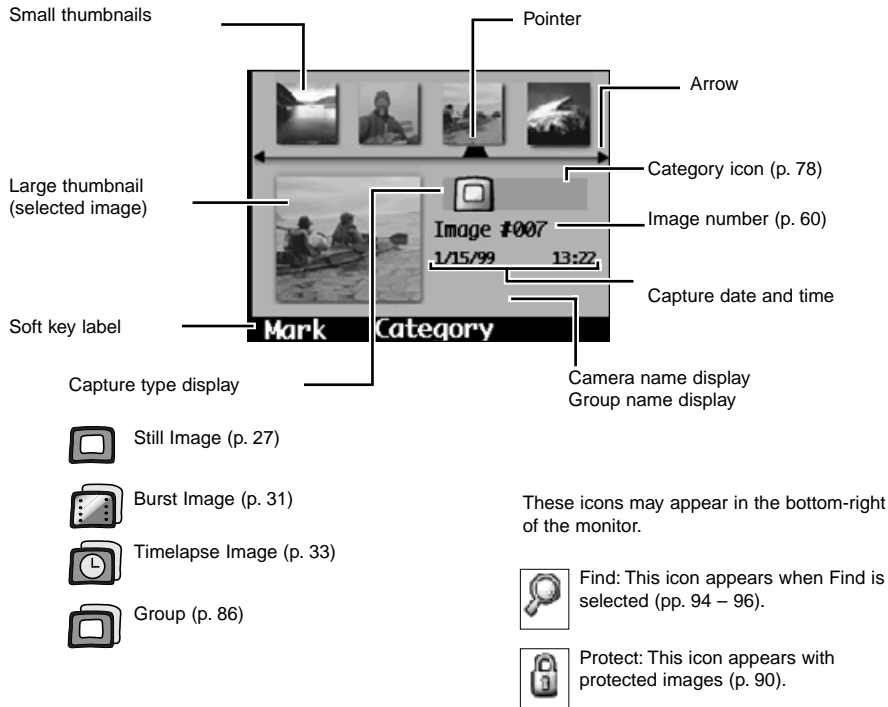

Reviewing/Selecting Images

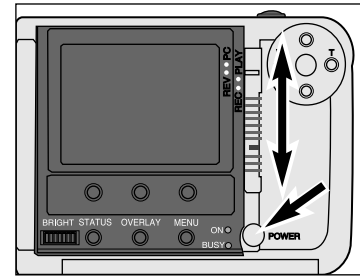

1 Turn the camera on.

2 While pressing the lock button, slide the mode switch to REV.
 • The Review screen will appear on the LCD monitor.



3 Press the Left and Right buttons to scroll through the thumbnails.
 • The pointer remains stationary while the small thumbnails scroll across the screen.



4 Select an image by scrolling through the thumbnails until the pointer is below the desired image and its large thumbnail is displayed.

• Once an image is selected, it can be categorized, grouped, protected, deleted, or marked.

📎 When performing functions, marked images receive priority over selected images.

MARKING IMAGES

Marked images have a 'notch' on the bottom right corner. Mark multiple images to perform one of the following actions on them:

- Category p. 78
- Group p. 86
- Delete p. 84
- Protect p. 90
- Send p. 91

MARK / MARK ALL



1 Press the Left or Right button to select the desired image.



2 Press the Mark soft key.

- A notch will appear at the bottom-right corner of the thumbnail.
- Marking the first image in a collapsed group will mark the entire group.

Mark all the images in the camera by holding the Mark soft key down for about 3 seconds, until the soft key label changes to Mark All.



MARKING IMAGES

UNMARK / UNMARK ALL



1 Press the Left or Right button to select the desired image.



2 Press the Unmark soft key.

- The notch will disappear from the bottom-right corner of the thumbnail.
- Unmarking the first image in a collapsed group will unmark the entire group.

Unmark all marked images by holding down the Unmark soft key for about 3 seconds, until the soft key label changes to Unmark All.



CATEGORY

The Category function allows you to add images to preset categories, represented by icons. A single, selected image can be added to a category or a set of marked images can be categorized. An image can belong to only one category.



1 Select an image (p. 75) or mark multiple images (p. 76).

2 Press the Category soft key.

- The Categories menu appears.



3 Use the Up and Down buttons to scroll through the category icons.

- The ▲ and ▼ marks indicate there are more menu items out of view. Press the Up or Down buttons to view the items.



4 Press the Select soft key to select the highlighted category.

- A ✓ mark appears next to the selected category, then the image(s) will be assigned to the new category and the camera will return to the Review mode screen.
- The Category icon for each image appears in the Review mode screen.

 A progress bar may appear if many images are being categorized.



CATEGORY

REMOVING IMAGES FROM A CATEGORY

Remove a single image from a category.



1 Select an image (p. 75).

2 Press the Category soft key.

- The Categories menu appears.



3 Use the Up and Down buttons to highlight the checked category.

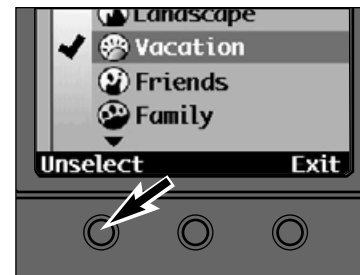

4 Press the Unselect soft key.

- The ✓ mark disappears then the image will be removed from the category and the camera will return to the Review screen.

EXPAND/COLLAPSE - OPEN/CLOSE

Burst, Timelapse, and Group images are represented in the Review screen by a single thumbnail image. It is possible to have all the thumbnails displayed for viewing by expanding the set. This also allows individual images within a set to be Marked, Deleted, etc. The Expand and Collapse soft key labels appear for Burst and Timelapse images. The Open and Close soft key labels appear for Grouped images.

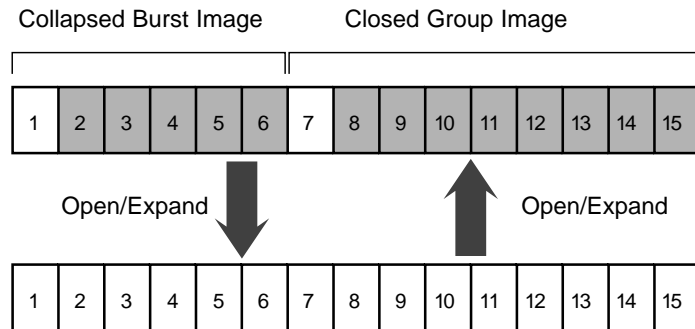

The white blocks represent images that are viewable. The gray blocks represent images that are hidden until the Open or Expand button is pressed.

EXPAND/OPEN

The Expand soft key label will appear when a set of images is selected.



Press the Expand or Open soft key.



The small thumbnails for all the images in the set will appear and a link icon will indicate the images are together.

The capture type of each image in the set will be displayed individually.

The procedure can be repeated for Burst or Timelapse images within a Group.

EXPAND/COLLAPSE - OPEN/CLOSE

COLLAPSE/CLOSE

The Collapse soft key label will appear when an expanded set of images is selected.



Press the Collapse soft key.

- The link icon will disappear and the set will be represented by only the first image.

Burst or Timelapse images within an Expanded Group can be collapsed independently.

An action (Mark, Delete, Protect, etc.) performed on a collapsed/closed set will be applied to the entire set.

REVIEW MODE MENUS

The Review mode menus allow you to delete unwanted images and protect important ones. They also give additional function options for more advanced operation, such as searching for images or organizing images into groups.

REVIEW MODE MENUS

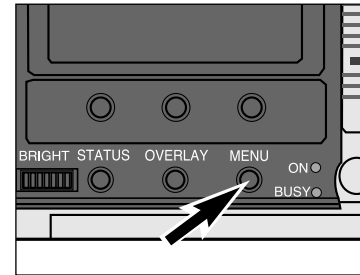

1 Turn the camera on and slide the mode switch to REV.

2 Press the menu button.

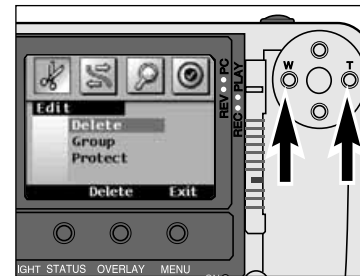

3 Press the Left or Right button until the desired menu appears.

• There are four menu options:

Edit
Camera - Camera
Find
Preferences

• A fifth menu option, Applications, is available if accessory applications have been added to the camera (p. 103).

REVIEW MODE MENUS

Edit:

Delete
Group
Protect

Find:

By Date
By Category

Camera-Camera:

Send...
Receive...

Preferences:

LANGUAGE
VIDEO MODE
NTSC
PAL

DELETING IMAGES

Delete unwanted images from the CompactFlash card in the camera. Use caution when deleting images. Images cannot be recovered once deleted. It is recommended that important images be protected before starting the delete function (p. 90).

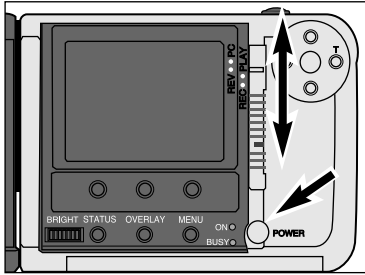

1 Turn the camera on and slide the Mode switch to REV.

- Press the green lock button while switching to REV from PLAY or REC.



2 Select a single image (p. 75), mark multiple images (p. 76), or select a group of images (pp. 75, 86)).



3 Press the menu button.

- The Review mode menus will appear.



4 Press the Left or Right button to select the Edit menu.

5 Press the Up or Down button to highlight Delete.

DELETING IMAGES

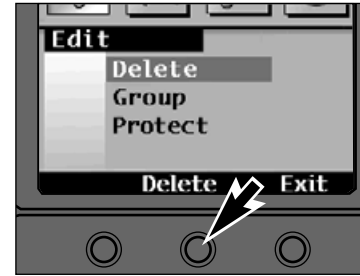

6 Press the Delete soft key.

- A confirmation screen will appear.
- Pressing the Exit soft key will return the camera to the Review screen.



7 Press the Start soft key.

- A progress bar may appear if there are many images to be deleted.
- Pressing the Exit soft key cancels the operation and returns the camera to the Review screen.

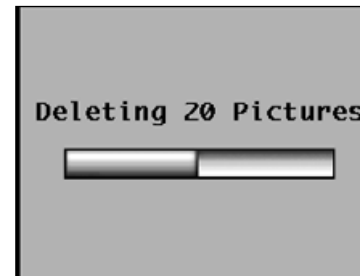

- When the operation is complete, the camera will return to the Review screen.

The image numbers of the remaining frames do not change.

CREATING A NEW GROUP

Create and name groups of images to aid in organization. An image can belong to only one group, but it can belong to a Category at the same time.



1 Turn the camera on and slide the Mode switch to REV.

- Press the mode lock button while switching to REV from PLAY or REC.

2 Mark multiple images or select a single image (p. 75, 76).

3 Press the Menu button.

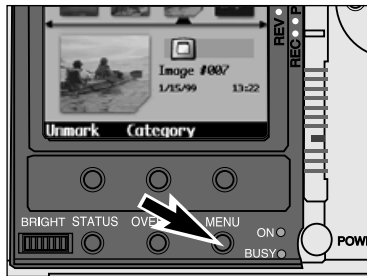

4 Press the Left or Right button until Edit is selected.

Press the Up or Down button until Group is highlighted.



5 Press the Add soft key.

- The Add to Group menu will appear.



6 Press the Create New soft key

- The Create New Group menu will appear.



7 Press the Up or Down button to select a character, then press the Right button to set the character and move to the next space.

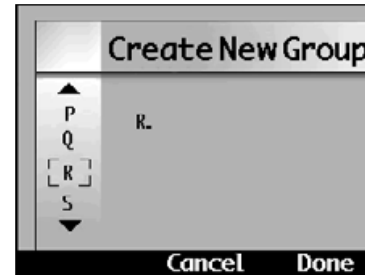

8 When the name is complete, press the Done soft key.

- The new group is created and the camera will return to the Edit menu.
- A group name can have up to 8 characters.

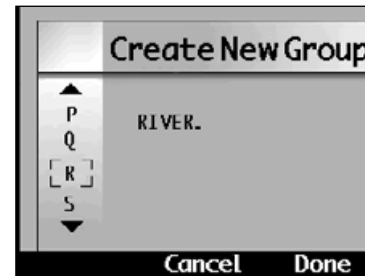

The images will appear with the Group name in the Review screen.
Group name has priority of Camera name in the display.



IMPORTANT: When a function (such as Mark or Delete) is applied to a closed group (p. 86), the function is performed to all the images in the group.

ADDING TO A GROUP

Add images to a group that already exists.

1 Follow steps 1 through 5 for “Creating a Group”.

- The Add to Group menu will appear.

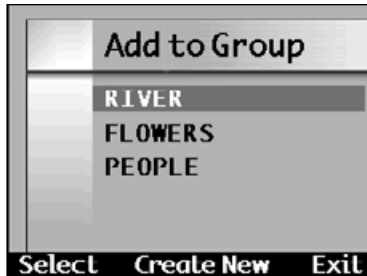

2 Press the Up or Down button to highlight a group.



3 Press the Select soft key to select the highlighted group.

- A 3 will appear next to the selection, then the camera will return to the Edit menu.

DISSOLVING A GROUP

Remove all the images from the group and delete the group name from the Group list. The images will remain on the compact flash card in the camera.

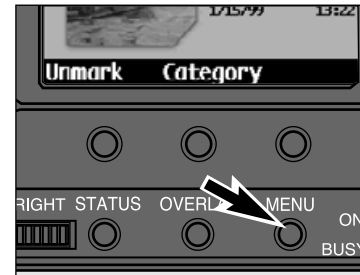

1 Turn the camera on and slide the Mode switch to REV.

- Press the mode lock button while switching to REV from PLAY or REC.

2 Select an image in the group (p. 75), then press the menu button.



3 Press the Left or Right button until Edit is selected.

Press the Up or Down button until Group is highlighted.

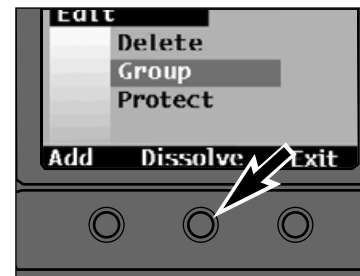

4 Press the Dissolve soft key.

- The Dissolve soft key is only available when a group is marked or selected.
- The Dissolve soft key will disappear when the operation is complete. Press the Exit soft key to return to the Review screen.

PROTECTING IMAGES

Important images can be write-protected to guard them from accidental deletion. Protected images cannot be removed from the compact flash card using the Delete function.

1 Turn the camera on and slide the Mode switch to REV.

- Press the green lock button while switching to REV from PLAY or REC.

2 Select a single image (p. 75), mark multiple images (p. 76), or select a group of images (pp. 75, 86).

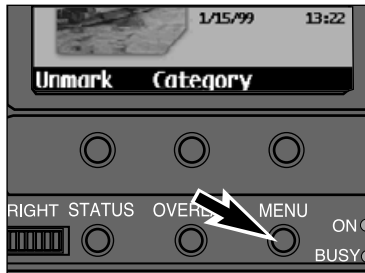

3 Press the menu button.

- The Review mode menus will appear.



4 Press the Left or Right button to select the Edit menu.

Press the Up or Down button to highlight Protect.

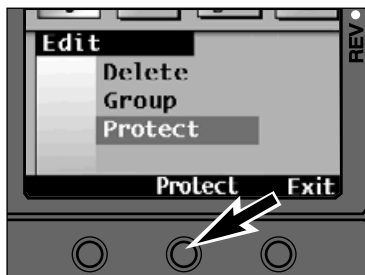

5 Press the Protect soft key.

- The camera will return to the Review screen when complete.
- The protect icon  will appear at the bottom-right of the Review screen when the protected image is selected.
- The Unprotect soft key appears when a protected image is selected. Use this soft key to unprotect images.
- The Exit key returns the camera to the Review screen.

TRANSFER CAMERA-CAMERA

It is possible to make a wireless transfer of images between two cameras that both use the Digita operating system and have IrDA interfaces. These instructions assume both the sending and receiving camera is a Minolta Dimage EX.

PREPARATION

1 Place the sending and receiving cameras so they face each other.

- The cameras should approximately 30 - 60cm (about 1 - 2 feet) apart.
- Be sure no obstructions are between the two cameras and nothing is blocking the IrDA sensors.

2 Turn both cameras on and slide the Mode switches to REV.

- Press the green lock button while switching to REV from PLAY or REC.

RECEIVING CAMERA

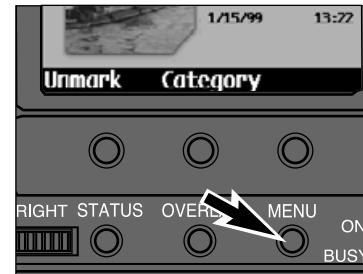

1 Press the menu button.

- The Review mode menus will appear.



2 Press the Left or Right button to select the Camera-Camera menu.

Press the Up or Down button to highlight Receive... .

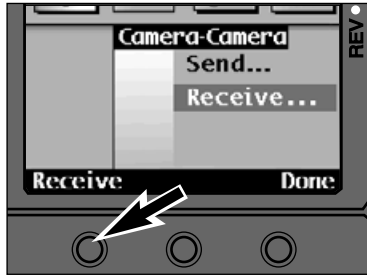

3 Press the Receive soft key.

- Waiting for Connection... will appear in the monitor.

The Done soft key returns the camera to the Review screen.



SENDING CAMERA

1 Select a single image (p. 75), mark multiple images (p. 76), or select a group of images (pp. 75, 86).

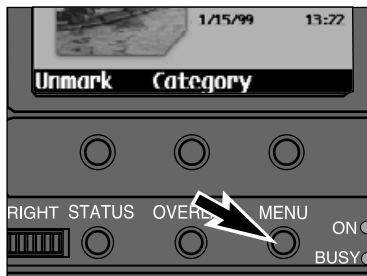

2 Press the menu button.

- The Review mode menu will appear.



3 Press the Left or Right button to select the Camera-Camera menu.

Press the Up or Down button to highlight Send... .

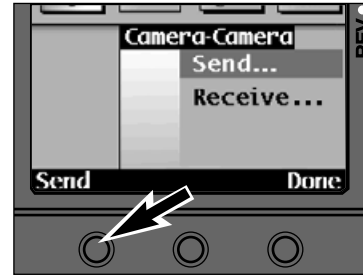

4 Press the Send soft key.

- A confirmation screen will appear.

The Done key returns the camera to the Review screen.

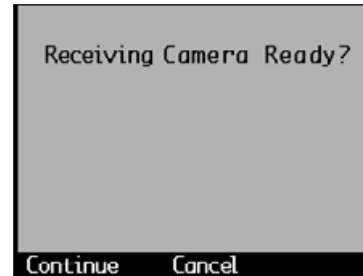

5 Check the receiving camera, then press the Continue soft key.

- The Connecting... message will appear, then a graph will indicate progress.

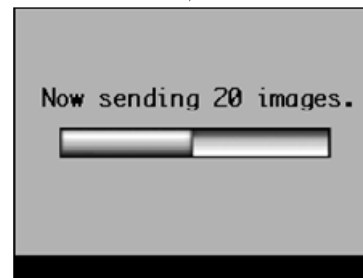

When the operation is complete, both cameras will return to the Camera-Camera menu.

Be sure there is enough space on the receiving camera's CompactFlash card before transferring images.

FIND - BY DATE

The find function lets you view images in the Review screen that were taken between certain dates.

1 Turn the camera on and slide the Mode switch to REV.

- Press the green lock button while switching to REV from PLAY or REC.

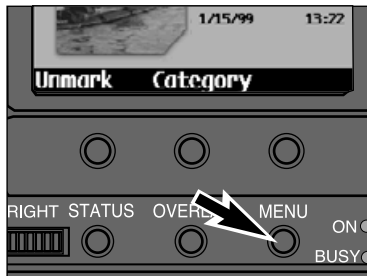

2 Press the menu button.

- The Review mode menus will appear.



3 Press the Left or Right button to select the Find menu.

4 Press the Up or Down button to highlight By Date.

5 Press the Edit soft key.

- The Find By Date screen will appear.

- The Exit key returns the camera to the Review screen.

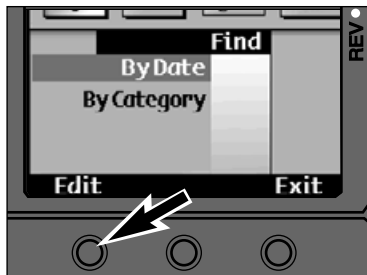

FIND - BY DATE

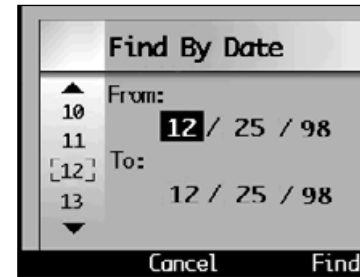

6 Press the Up or Down button to select a number, then press the Right button to set the character and move to the next space.

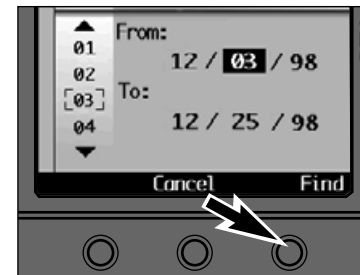
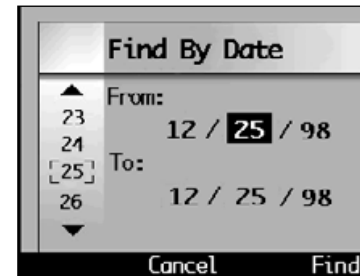

7 Press the Find soft key.

- The camera will return to the Review screen to view the find results.

- The Cancel key returns the camera to the Review screen without executing the find function.



- The found images will appear in the Review screen in chronological order.

- The magnifying glass icon will appear in the screen as a reminder that the images are filtered.

- The Show All soft key turns off the Find function and displays all the images in the camera.

FIND - BY CATEGORY

The find function lets you view images in the Review screen that belong to a certain categories.

1 Follow steps 1 - 3 from Find - By Date (p. 94)



2 Press the Up or Down button to highlight By Category.

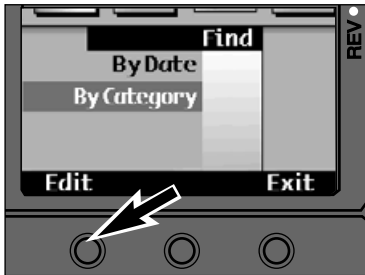

3 Press the Edit soft key.

- The Categories screen will appear.

 The Exit key returns the camera to the Review screen.

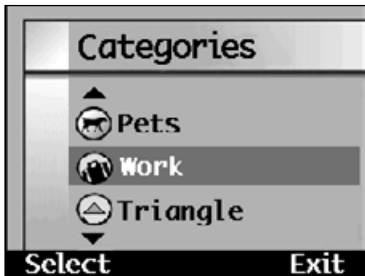

4 Press the Up or Down button to highlight a category.

5 Press the Select soft key.

- A ✓ will appear next to the selected category, then the camera will return to the Review screen to view to find results.
- The Exit key returns the camera to the Find menu without executing the find function.
- The found images will appear in the Review screen in chronological order.

- The  icon will appear in the screen as a reminder that the images are filtered.
- The Show All soft key turns off the Find function and displays all the images in the camera.

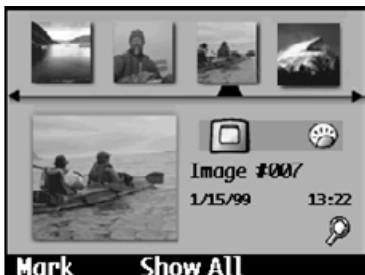

LANGUAGE

Cameras purchased in Europe have multiple languages available for the interface.

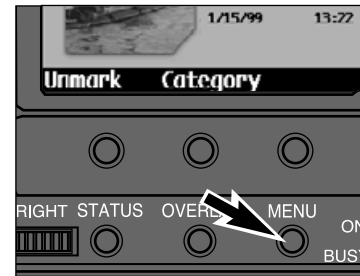

1 Turn the camera on and slide the Mode switch to REV.

- Press the green lock button while switching to REV from PLAY or REC.

2 Press the menu button.

- The Review mode menus will appear.



3 Press the Left or Right button to select the Preferences menu.

4 Press the Up or Down button to highlight Language.

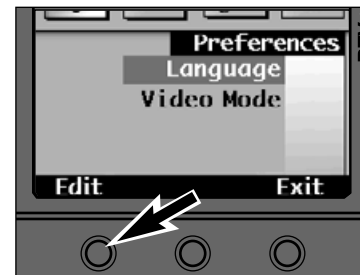

5 Press the Edit soft key.

- The Language menu will appear.

 The Exit key returns the camera to the Review screen.



6 Press the Up or Down button to highlight the desired language.

7 Press the Select soft key.

VIDEO MODE

It is possible to view images in the camera on your television. This camera has a video-out terminal which allows you to connect the camera to your television using the Video Cable VC-EX1. This camera is compatible with both the NTSC and PAL television systems. The system used by your television is determined by the country in which you live.

NTSC

U.S.A, Canada, Mexico, Phillipines, Japan, and South Korea.

PAL

England, Australia, Germany, Italy, Switzerland, Holland, Singapore, Thailand, China, and most European countries*.

*France uses the SECAM system.

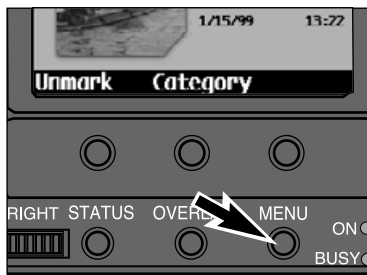

- 1 In Review Mode, press the menu button.**

- The Review mode menus will appear.



- 2 Press the Left or Right button to select the Preferences menu.**

- 3 Press the Up or Down button to highlight Video Mode.**

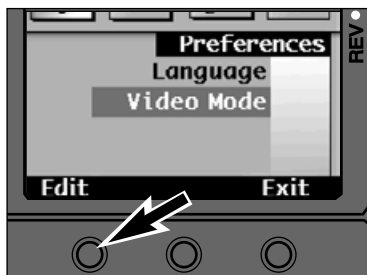

- 4 Press the Edit soft key.**

- The Video Mode menu will appear.

- The Exit key returns the camera to the Review screen.

VIDEO MODE

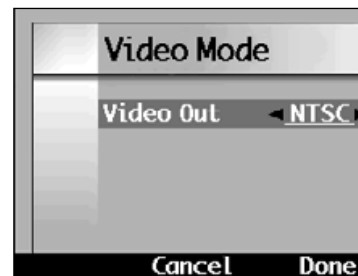

- 5 Press the Left or Right button to select the desired mode.**

- 6 Press the Done soft key.**

CONNECTING THE CAMERA TO THE TELEVISION

- 1 Turn off the television and the camera.**

- 2 Remove the terminal cover on the camera. Insert the mini plug end of the Video Cable VC-EX1 into camera video out terminal.**

- There will be no display on the camera's LCD monitor when the VC-EX1 is attached to the camera.

- 3 Plug the other end of the Video Cable VC-EX1 into the video input terminal on the television.**

- 4 Turn the television and the camera on.**

- 5 Slide the camera's mode switch to REV or Play.**

- 6 Change the television to the video channel.**

- The camera's normal Review or Play mode display will appear on the television screen.

- 7 Scroll through the images using the normal camera operations.**

APPENDIX

ACCESSORIES

There are various accessories sold separately for this camera. For more information, please contact your camera dealer, PC dealer, or a Minolta Service Facility.

Dimâge EX WIDE 1500 Lens Unit

The Dimâge EX WIDE 1500 f/1.9, 28mm (35mm equivalent) detachable lens unit featuring 1.5 million pixel progressive scan, and a high resolving power is also sold separately.

Dimâge EX ZOOM 1500 Lens Unit

The Dimâge EX ZOOM 1500 f/3.5-5.6, 38-115mm (35mm equivalent) detachable lens unit featuring 3X zoom, 1.5 million pixel progressive scan, and a high resolving power is also sold separately.

Lens Extension Cable LC-EX1

The Lens Extension Cable LC-EX1 allows the lens unit to be detached from the camera and used to photograph from a variety of angles.

AC Adapter

The AC Adapter allows the camera to receive power from an electrical outlet. Use of the AC adapter is recommended to conserve batteries during periods of heavy use. It is also recommended when using the IrDA for image transfer or controlling the camera remotely with the computer.

CompactFlash Cards RM-8C/RM-16C/RM-32C

These accessory Compact Flash cards have 2 times/4 times/8 times the storage space of the standard 4MB CompactFlash card.

PC Card Adapter CA-1C

This adapter allows CompactFlash cards to be used in PCMCIA card drives (ATA PCMCIA Type II standard). This is convenient for quick data transfer.

CUSTOM SCRIPTS

Script is a program that uses the Digita™ Operating Environment. Scripts expand the camera functions or allow automated work flow. Scripts can be run independently from normal camera operations. For more information on scripts, contact a Minolta Service facility or visit the FlashPoint Technology, Inc. world wide web site.



When a script is installed, the Custom Script menu option is available. The Custom Script menu will appear in the Record mode menu screen.

APPLICATIONS

Applications are additional pieces of software, available as an accessory and designed for cameras using the Digita™ Operating Environment, that can be loaded onto your camera using a CF card. These applications add functions to your camera, such as applying a filter effect on recorded images or connecting images to create a panoramic shot. See your dealer, contact a Minolta Service Facility for details, or visit the FlashPoint Technology, Inc. world wide web site.



When an application is installed, the Applications menu option is available. The Applications menu will appear in the Review mode menu screen.

FILE SIZE

The file size of the image is determined by the selected Image Size and Image Quality. There are two options for Image Size; **Full (1344 x 1008 pixels)** and **1/4 (640 x 480 pixels)**. See page 46. There are four Image Quality (compression) options; **Super Fine (1:2)**, **Fine (1:7)**, **Standard (1:19)**, and **Economy (1:38)**.

The actual file size will be determined by the scene. Some images will be able to compress further than others. The table below is a list of average file sizes.

APPROXIMATE FILE SIZES

| | S. FINE | FINE | STD. | STD. |
|-----------|---------|-------|-------|-------|
| Full Size | 1500KB | 540KB | 200KB | 100KB |
| 1/4 Size | 500KB | 180KB | 100KB | 50KB |

CARD CAPACITY

The number of images that can fit on a compact flash card is determined by the size of the card (such as 4MB, 8MB, 16MB, or 32MB) and the file size of the images. The actual file size will be determined by the scene. Some images can be compressed further than others. The table below is an approximated list of the number of average images that can fit on a compact flash card.

APPROXIMATE CARD CAPACITY

| | S. FINE | FINE | STD. | STD. |
|-----------|---------|----------|-----------|------------|
| Full Size | 2/5/10 | 7/15/30 | 20/40/80 | 40/80/160 |
| 1/4 Size | 7/15/30 | 20/45/90 | 40/80/160 | 80/160/320 |

Listed in **number of images** for **4MB/8MB/16MB** compact flash cards.

TROUBLESHOOTING

Refer to these pages to determine the cause of a problem you are experiencing with the camera. If the information does not cover the problem which you are experiencing, contact a Minolta Service Facility.

| Problem | Cause | Solution |
|-------------------------------------|---|--|
| No image appears in the LCD monitor | The camera is not turned on. | Press the main switch (labelled "Power") to turn the camera on. |
| | The batteries are exhausted. | Replace all four batteries or use the AC Adapter (sold separately). |
| | The batteries are inserted incorrectly. | Insert the batteries correctly. Use the polarity (+/-) diagram on page 17. |
| | There is no CompactFlash card in the camera. | Insert a CompactFlash card into the camera (p. 21). |
| | The camera is in Record mode (Mode Switch is on REC) and the display button has not been pressed. | The display button must be pressed to turn on the display each time the camera is switched to Record mode (p. 27). |
| | The LCD brightness has been turned down too low. | Turn the brightness dial to the desired level (p. 23). |

TROUBLESHOOTING

| Problem | Cause | Solution |
|-------------------------------------|--|---|
| The camera will not take a picture. | The camera is off. | Press the main switch (labelled "Power") to turn the camera on. |
| | The camera is not in Record mode. | Slide the Mode Switch to REC (p. 27). |
| | The camera is processing, Please Wait appears in the overlay bar. | Wait until Ready appears in the overlay bar. |
| | The CompactFlash card is full, No space on card appears in the overlay bar. | Delete unwanted images, transfer card contents to the PC then erase the card, or use a new CompactFlash card. |
| | Problem | Cause |
| Pictures are out of focus. | The subject has low contrast or other characteristic that is difficult for the autofocus system. | Use Focus Hold on another object that is similar distance to you as your subject (p. 37). Read Focus section (p. 36). |
| | The subject is too close to the camera. | Be aware of the minimum focus distance of your lens, listed on page 36. |

| Problem | Cause | Solution |
|---|--|--|
| Autofocus is not working. | The camera is in Macro mode (Zoom 1500 lens only). | Autofocus does not operate in Macro. Use the Left and Right buttons to focus manually or turn Macro off (p. 42). |
| Using flash, the picture is too dark. | The subject is beyond the flash range. | |
| | The flash is not charged. | The orange flash lamp blinks when the shutter-release button is pressed partway down while the flash is charging. Wait until the flash lamp glows. |
| All the images are too dark or too light. | Exposure compensation is not set to 0. | Set the exposure compensation value to 0 (p. 43). |
| The image file is corrupt. | The CompactFlash card was removed while the camera was accessing the card. | Never remove a CompactFlash card when the Busy lamp is blinking. It is best to turn the camera off before removing or inserting a CompactFlash card. |

OPERATING TEMPERATURES AND CONDITIONS

- This camera has been designed for use from 0°C to 40°C (32° to 104°F).
- Never leave the camera where it may be subjected to extreme temperatures, such as the glove compartment of a car.
- Do not subject the camera to extreme humidity.
- To prevent condensation from forming, place the camera in a sealed, plastic bag when bringing it from the cold exterior to a warm building. Allow it to come to room temperature before removing it from the bag.
- Battery performance decreases with lower operating temperatures. When photographing in cold weather, it is recommended that you keep the camera and spare batteries inside your coat to keep them warm when you are not shooting. Cold batteries will regain some of their charge when they warm up.
- Occasionally, when using alkaline batteries the low-battery symbol may appear even if there is enough charge. Continue to use the camera. The low-battery symbol will disappear.

HANDLING CARE

- The Dimâge-EX is neither waterproof nor splashproof.
 - Inserting/removing batteries or CompactFlash cards with wet hands may damage the camera.
 - Take care when using the camera at the beach or near water. Costly or irreparable damage may occur.
- Do not subject the camera to shock or impact.
- Do not leave the camera in direct sunlight. Do not point the lens at direct sunlight. CCD damage may occur.
- Turn the camera off or remove the batteries when transporting.

LCD MONITOR CARE

- The LCD monitor is a precision device with a pixel efficiency of 99.98%. Less than 0.02% of the pixels are dysfunctional.
- Do not apply pressure on the surface of the LCD monitor. Permanent damage may occur.
- In low temperatures, the LCD monitor will temporarily darken. When the camera warms-up, normal display will be restored.
- If the + or – buttons are pressed rapidly during playback, images may appear to overlap. This is normal and the image data is not changed.
- If the LCD monitor surface is dirty, first blow away dust or sand, then gently wipe it with a soft, clean, dry cloth.
- If the LCD display blinks continuously or no longer works at all, it is time to replace the monitor. Take the camera to your dealer or a Minolta Service Facility listed on the back cover of this manual.

CLEANING

- If the camera or lens is dirty, gently wipe it with a soft, clean, dry cloth. If the camera or lens comes in contact with sand, gently blow away loose particles, wiping may scratch the surface.
- To clean the lens surface, first brush away any dust or blow away sand, then, if necessary, moisten a lens tissue with lens cleaning fluid and gently wipe the lens.
- Never use organic solvents to clean the camera.
- Never touch the lens surface with your fingers.

STORAGE

- Remove the batteries from the camera when not in use for an extended period. Damage may result if battery leakage occurs.
- Store in a cool, dry, and well-ventilated area away from dust and chemicals (such as mothballs). For very long periods, place the camera in an airtight container with a silica gel drying agent.
- Before using after prolonged storage, check the camera's operation to make sure it is functioning properly.

BEFORE IMPORTANT EVENTS

- Always check the camera's operation carefully or take test photographs.
- Minolta is not responsible for damages incurred by equipment malfunction.

QUESTIONS AND SERVICE

- If you have questions about your camera, contact your local camera dealer or write to the Minolta distributor in your area.
- Before shipping your camera for repair, please contact a Minolta Service Facility for details.

SAFETY AND HANDLING FOR COMPACT FLASH CARDS

- Read and follow the instructions that accompanied the CompactFlash card.
- The following may cause data loss or damage:
 - Improper use of card.
 - Static electrical discharge near card or electric noise.
 - Removing the card or interrupting power supply while camera or drive is accessing the card (reading, deleting, etc.).
 - Non-use of card for an extended period. Data stored on CompactFlash cards will degrade over time. Data left on a card for extensive periods may not be recoverable.
 - Wear from ordinary use.
- The storage capability of CompactFlash cards will diminish with extended use. When this occurs, please purchase a new card.
- Do not bend, drop, or subject the card to impact.
- Keep away from static electricity and electric noise.
- When not in use, return the card to its protective case.
- All data on the card is permanently erased when the card is formatted.
- Do not touch the electrical contacts of the card with your fingers or a metal object.
- Keep away from heat, moisture, and direct sunlight.
- Keep away from small children.

TECHNICAL DETAILS

| | |
|----------------------------|--|
| TYPE | Compact digital camera with autofocus (AF), autoexposure (AE), auto white balance (AWB), detachable lens unit, built-in LCD, Digita™ Operating Environment, and built-in flash |
| CCD | 1/2 inch, square pixels, progressive scan Sony Wfine CCD™ with primary colour filter. Total number of pixels: approx. 1,500,000 pixels. Number of effective pixels: approx. 1,450,000 pixels. |
| ZOOM 1500 LENS UNIT | Lens: 7 - 21mm f/3.5 – 5.6 (35mm camera equivalent: approx. 38 - 115mm), with macro capability. Construction: 5 element, 5 group zoom including 3 aspheric surfaces. Focusing range: 0.5m-infinity, 0.35-0.5m in macro mode Viewfinder: real-image optical viewfinder |
| WIDE 1500 LENS UNIT | Lens: 5.2mm f/1.9 (35mm camera equivalent: approx. 28mm) Construction: 9 elements in 8 groups Focusing range: 0.3m-infinity Viewfinder: real-image optical viewfinder |
| IMAGE STORAGE | Recording Media: CompactFlash Card File format: Exif 2.0 (JPEG) Number of pixels: 1,344 x 1,008 / 640 x 480 pixels Image compression ratio: SUPER FINE (1:2), FINE (1:7), STANDARD (1:19), ECONOMY (1:38) Storage capacity* (approximate): SUPER FINE: 2 images, FINE: 7 images, STANDARD.: 20 images, ECONOMY: 40 images (* Using a 4MB CompactFlash in Full Size; 1,344 x 1,008 pixels) |
| AUTOFOCUS | External passive AF system (focus aid available in macro mode) |
| EXPOSURE | Programmed AE Exposure compensation (+/- 2 EV in 1/3 EV increments) Metering: 25-segment TTL metering ISO equivalent: approx. 125 Shutter speed: 1/4,000 sec. - 2 sec. |
| WHITE BALANCE | Automatic; manual setting available (daylight, tungsten, fluorescent) |

| | |
|------------------------------|--|
| FLASH | Guide number: 11 (ISO 125) Coverage: 28mm angle of view (35mm format equivalent) Flash modes: autoflash, fill-flash, flash cancel, autoflash with red-eye reduction, and fill-flash with red-eye reduction Automatic flash metering |
| LCD MONITOR | Type: 2.0 inch low temperature poly-silicon colour TFT-LCD module Pixels: approximately 110,000 |
| DRIVE MODES | Still Capture: faster than 1 frame/2 seconds Burst Capture: Max. 3.5 frames per second (in 1,344 x 1,008 pixels, up to 7 frames; in 640 x 480, up to 15 frames) Timelapse: Set to capture at user-selected intervals; 60 - 32767 seconds: selectable by seconds 1 minute - 546 minutes: selectable by minutes Self-timer: Approx. 10 second delayed release |
| INTERFACE | Video output: NTSC, PAL (user selectable) Digital: Serial: RS-232C (for PC Serial Adapter) Wireless: IrDA Ver. 1.0 |
| POWER | Battery: Four AA-size alkaline batteries (AA-size Ni-Cd, AA-size Ni-MH, AA-size lithium batteries are also usable) |
| OPERATING TEMPERATURE | 0 - 40 °C (32 - 104 °F) |
| DIMENSIONS (WxHxD) | Dimâge EX ZOOM 1500: 127.5 x 67.5 x 58.5mm Dimâge EX WIDE 1500: 127.5 x 67.5 x 62.5mm |
| WEIGHT | Dimâge EX ZOOM 1500: 310g (with lens, without batteries) Dimâge EX WIDE 1500: 340g (with lens, without batteries) |

Specifications are based on the latest information available at the time of printing and are subject to change without notice.

LATE-BREAKING INFORMATION

This insertion contains important late-breaking information about the Dimâge EX and included software. Please read this information carefully and review it with the proper section of the appropriate instruction manual.

Please register your software to receive software upgrade information.

LCD Monitor - page 23

When the camera is turned on in Record Mode, the LCD monitor automatically turns on. When the camera is changed to Record Mode from another mode, the LCD monitor resumes the Record mode's last ON/OFF position.

Burst Mode - page 31

Processing of a Burst Image series takes approximately three minutes. During this time, another Burst series cannot be taken. However, the mode can be changed and Still images can be taken.

Image Quality Default Settings - page 47

The default image quality setting for all image types (Still, Burst, and Timelapse) is Standard (STD).

Bracketing Sequence - page 56

The exposure sequence for Bracketing is: under, normal, over.
Before starting a bracketing sequence, be sure the Busy lamp is not glowing. (Bracket operation is unpredictable if a series is started when the busy lamp is glowing.)

Formatting CompactFlash Cards - page 62

After formatting the CompactFlash card with the Dimâge EX, turn the camera off once, then turn the camera on again.

Review Mode Display - page 74

The file name for uploaded images will not be displayed.

Custom Scripts - page 102

For details regarding the Digita Script software development kit, visit the FlashPoint Technology home page at <http://www.flashpnt.com/>

- Depending on the contents of a specific script, certain scripts may cause instability in the camera's operation.
- Minolta is not responsible for the results of user-made custom scripts used with the Dimâge EX.

CompactFlash Card Maximum Capacity - page 105

It is recommended that the maximum number of images recorded on a CompactFlash card in the Dimâge EX does not exceed 200. If more than 200 images are recorded on a CompactFlash card in the camera, camera operation may be unpredictable.

Camera Malfunction

When the camera locks-up ('freezes'), remove and reinsert the batteries or unplug and replug in the AC adapter.

Turning the Camera On

Before turning the camera on, slide the mode switch to REC or PLAY.

Blinking Busy Lamp

Do not open the battery/card-chamber cover or unplug the AC adapter while the Busy lamp is blinking.

Compact Flash Cards used with a Compact Flash Adapter

This information is for customers using compact flash cards in PCMCIA drives with a compact flash card adapter.

The compact flash card will contain a folder titled EX15_01 (Fig. 1). Inside this folder are the image files and a file titled Ftifold.inf (Fig 2).

Fig. 1

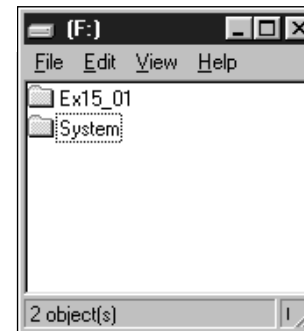

Fig. 2



The Ftifold.inf file contains the image management information for the compact flash card. This file is only updated when images are added or deleted via the Dimâge EX camera. When images are added to or deleted from the card directly through the disk drive, the file is not updated - this can cause unstable operation.

Delete images from or upload images to the compact flash card in the Dimâge EX via the Digita Desktop™ software, or use the delete function on the Dimâge EX to remove images from the compact flash card.

- A** Minolta Austria Ges.m.b.H
Amalienstr. 59-61, A-1131 Wien,
Österreich
Tel: 01 87868 176 Fax: 01 87868 153
<http://www.minoltaeurope.com>
- B** Minolta Belgium Branch
Kontichsesteenweg 38, B-2630
Aartselaar, Belgique
Tel: 03 877 04 30 Fax: 03 877 00 49
<http://www.minolta.be>
- CAN** Minolta Canada Inc., Head Office
369 Britannia Road East,
Mississauga, Ontario L4Z 2H5, Canada
Tel. 0905 890 66 00 Fax: 0905 890 71 99
<http://www.minolta.com>
- CH** Minolta (Schweiz) AG
Riedstr. 6, CH-8953 Dietikon, Schweiz
Tel: 157 57 11 Fax: 01 741 33 12
<http://www.minolta.ch>
- D** Minolta GmbH
Kurt-Fischer-Str. 50, D-22923
Ahrensburg, Deutschland
Tel: 0180 567 20 80 Fax: 0221 93 767
177
Mo – Fr, 10.00 – 19.00
<http://www.minolta.de>
- DK** Paul Westheimer A/S
Erhvervsvej 30, DK-2610 Rødovre,
Danmark
Tel: 44 85 34 00 Fax: 44 85 34 01
<http://www.minoltaeurope.com>
- E** Videosonic S.A.
c/ Valportillo II, 8, Pol. Ind. de
Alcobendas,
E-28100 Alcobendas/Madrid, Spain
Tel: 01 661 94 30 Fax: 01 661 94 30
<http://www.minoltaeurope.com>
- F** Minolta France S. A.
365, Route de Saint-Germain,
F-78420 Carrières-Sur-Seine, France
Tel: 0130 86 62 02 Fax: 0130 86 62 82
<http://www.minolta.fr>
- FIN** Minolta Finland Branch
Niittykatu 6, PL 37 SF-02201 Espoo,
Finland
Tel: 09 423 499 Fax: 09 423 116
<http://www.minolta.fi>
- GB** Minolta (UK) LTD. Photographic Division
Precedent Drive,
Rooksley, Milton Keynes, MK13 8HF,
England
Tel: 01 908 208 349 Fax: 01 908 208 334
<http://www.minolta.co.uk>
- IRL** Photopak Sales
241 Western Industrial Estate, Naas
Road, Dublin 12, Ireland
Tel: 01 45 66 400 Fax: 01 45 00 452
<http://www.minoltaeurope.com>
- I** Rossi & C. S.p.A.
Via Ticino 40, Sesto Fiorentino-Firenze, I
– 50019 Osmannoro, Italy
Tel: 055 31 60 02 Fax: 055 37 52 87
<http://www.minoltafoto.it>
- N** Scandiafilm AS
Enebakkveien 304, N-1188 Oslo 11,
Norge
Tel: 022 28 00 00 Fax: 022 28 17 42
<http://www.minoltaeurope.com>
- NL** Minolta Camera Benelux B. V.
Zonnebaan 39, P. O. Box 6000,
NL-3600 HA, Maarssen, Nederland
Tel: 030 241 14 11 Fax: 030 241 41 65
<http://www.minolta.nl>
- P** Minolta Portugal Lda
Av. do Brasil 33-a, P-1700 Lisboa,
Portugal
Tel: 01793 00 16 Fax: 01 793 10 64
<http://www.minoltaeurope.com>
- S** Minolta Svenska AB
P. O. Box 9058, Albygatan 114, S-17109
Solna, Sverige
Tel: 08 627 76 50 Fax: 08 627 76 21
<http://www.minoltaeurope.com>
- Sin** Minolta Singapore (Pte) Limited
10 Teban Gardens Crescent, Singapore
2260
Tel: 56 35 533 Fax: 56 10 217
<http://www.minolta.com>

Please contact your dealer for additional information. If your dealer is unable to help you, contact us.

Technical Support
01908 208349
Monday - Friday 9:00 AM - 5:15 PM
Minolta (UK) Limited
Photographic Division
Rooksley Park
Precedent Drive
Rooksley
Milton Keynes
MK13 8HF

MINOLTA

Dimâge EX

Version 2

This part explains the changes incorporated in the Dimâge EX Operating Environment Version 2. (firmware)
Please read it in conjunction with the User's Manual supplied with the camera.

1. A NEW DIGITAL MAGNIFICATION FUNCTION120

2. INCREASED BURST RATE121

3. SMOOTHER MOTION IN LIVE IMAGES121

4. THE INTERNAL FLASH MAY BE SWITCHED ON/OFF121

5. A FLASH BRACKETING FUNCTION HAS BEEN ADDED122

6. CUSTOM SETTINGS FOR WHITE BALANCE HAS BEEN ADDED123

7. IMPROVED CUSTOM SCRIPT FUNCTION124

8. THE BRACKETING INCREMENTS HAS BEEN CHANGED125

Ver. 2!

NEW FEATURES FOR DIMAGE EX VERSION 2

1. A NEW DIGITAL MAGNIFICATION FUNCTION

After extending the optical zoom (telephoto) to 115mm, release the right button and then press it again to select digital magnification. Press the right button once to increase the magnification of the live image on the LCD monitor. The full size (2.0X) image is 672 pixels (horizontal) x 504 pixels (vertical) (1/4 size (2.2X) image of 288 pixels (horizontal) x 216 pixels (vertical)).

Press the left button once to decrease the digital magnification of the image. After decreasing magnification to the minimum size image of 1344 pixels (horizontal) x 1008 pixels (vertical) (1/4 size image of 640 pixels (horizontal) x 480 pixels (vertical)), press the left button once to re-select the optical zoom (telephoto).

A magnifying glass icon  appears at the top-right of the REC screen when digital magnification is selected.

| Trimmed area (displayed area) with digital magnification | | | | Magnification for digitally magnified area. Figures in brackets are for 1/4 size. |
|--|-----------------|----------------|-----------------|---|
| Full size | | 1/4 size | | |
| Width (pixels) | Height (pixels) | Width (pixels) | Height (pixels) | |
| 1344 | 1008 | 640 | 480 | 1.0X (1.0X) |
| 1120 | 840 | 576 | 432 | 1.2X (1.1X) |
| 1024 | 768 | 512 | 384 | 1.3X (1.3X) |
| 960 | 720 | 448 | 336 | 1.4X (1.4X) |
| 896 | 672 | 384 | 288 | 1.5X (1.7X) |
| 768 | 576 | 320 | 240 | 1.8X (2.0X) |
| 672 | 504 | 288 | 216 | 2.0X (2.2X) |

- The digital magnification function operates only when the LCD monitor is switched ON. When digital magnification has been selected it is cleared by pressing the LCD monitor ON/OFF button on the lens unit to switch the monitor OFF.
- Digital magnification cannot be used when the wide-angle 1500 lens unit is fitted.
- When the PLAY or REVIEW mode is selected while digital magnification is selected, selecting the REC mode again clears digital magnification.
- Motion in digitally magnified live images is slightly jerky with digital magnification selected, however this has no effect on image quality.
- Images recorded from the digitally magnified area are trimmed in the vertical and horizontal directions as shown above (they are not reconstructed to 1344x1008 pixels), and appear as smaller images when displayed on the PC monitor screen or when printed.

2. INCREASED BURST RATE

(see User's Manual P52)

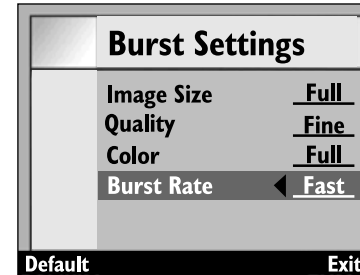

The burst rate is increased when [Fast] or [Medium] is selected with Menu Button → [Media Settings] → [Burst] → Edit soft key → [Burst Settings] → [Burst Rate].

- [Fast] Approximately 3.5 frames per second
New: → Approximately 7.5 frames per second
- [Medium] Approximately 2.5 frames per second
New: → Approximately 3.7 frames per second

The burst rate when [Slow] is selected (approximately 1.2 frames per second) has not changed.

3. SMOOTHER MOTION IN LIVE IMAGES

The refresh rate (the time required to rewrite one frame on the LCD monitor) when reviewing live images has been increased by approximately 33%, thus improving the smoothness of motion.

- Motion in digitally magnified live images is slightly jerky with digital magnification selected. However, this has no effect on image quality.

4. THE INTERNAL FLASH MAY BE SWITCHED ON/OFF

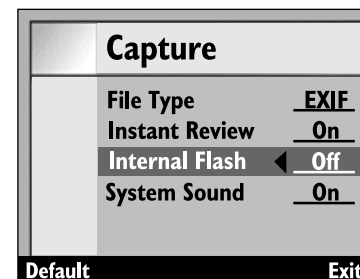

The internal flash may be switched ON/OFF by selecting Menu Button → [Preferences] → [Capture] → Edit soft key → [Capture] [Internal Flash]

This function allows the internal flash to be switched OFF when using the external flash unit FL-EX1 (available separately).

- [On] Internal flash operates
- [Off] Internal flash does not operate

- Setting this function to disable the internal flash does not disable the pre-flash for use in reducing red-eye and the AF flash assistance used for focusing.

5. A FLASH BRACKETING FUNCTION HAS BEEN ADDED

By changing the flash illumination in steps the exposure for the background not reached by the flash remains unchanged, while the exposure for the subject illuminated by the flash is bracketed. The exposure for the subject is bracketed from 'optimum' → 'under exposed' → 'over exposed'.

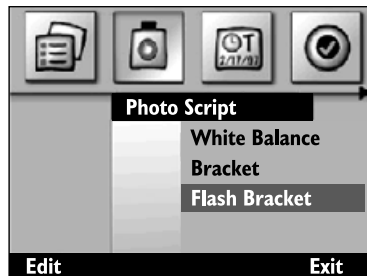

1 Display the menu screen using the menu button, highlight [Photo Script] → [Flash Bracketing] and press the Edit soft key.

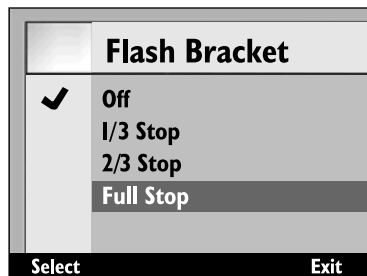

2 Highlight the bracketing adjustment increment required, and press the Select soft key.

3 Wait until the flash is charged, and then press the shutter button to take the photograph.

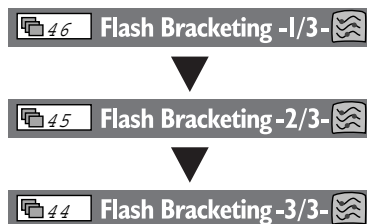

4 Repeat step 3. above twice.

- This differs from the Bracketing (see P56 of the User's Manual) in that the shutter is pressed three times for each series of three exposures.
- When flash bracketing is selected, the numbers at the right of the overlay bar indicate whether the next photograph is the 1st, 2nd, or 3rd of the three frames.
- Use flash bracketing only after checking that the BUSY lamp is extinguished. Flash bracketing will not operate correctly if photography is begun while this BUSY lamp is lit (blinking).

6. CUSTOM SETTINGS FOR WHITE BALANCE HAS BEEN ADDED

(see User's Manual P55)

In addition to the preset white balance the Dimâge EX allows custom setting of white balance in accordance with the user's own white balance sample.

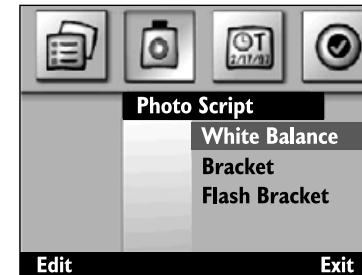

1 Display the menu screen using the menu button, highlight [Photo Script] → [White Balance], and press the Edit soft key.

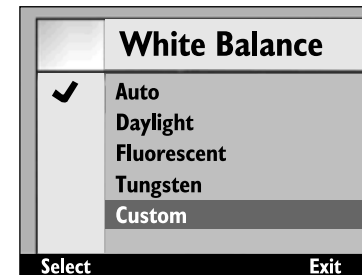

2 Highlight [Custom].

3 Point the lens towards the white balance sample and press the Select soft key.

- The custom white balance is set.
- Ensure that the white balance sample is large enough to fill the viewfinder.
- After the custom white balance is set the screen returns to the condition in step 1. above. Press the End soft key to return to the initial (live image) screen.
- A custom white balance once set is maintained until another white balance is selected, or the camera power supply is switched OFF. Switching the camera power supply OFF clears the custom white balance.

7. IMPROVED CUSTOM SCRIPT FUNCTION

(see User's Manual P102)

The script facility of the Dimage EX has been improved to allow more flexibility in writing scripts. Below are some examples. These can be downloaded from the Minolta website, http://minoltaeurope.com/download_link.html

Shutter Speed Setting

The manual exposure mode is selected from the menu and the desired shutter speed is set (the f-stop cannot be changed) using a script. Use when a shutter speed of longer than 2 seconds is required.

Changing ISO Sensitivity

Automatic gain control operates to amplify the signal when the subject is dark and the signal level is low. Note that gain is normally fixed. However, it may be altered with the script. Please note that the noise in the signal may increase as the gain is increased.

Flash Compensation

The flash illumination may be controlled for exposure compensation using a script. This compensation differs from the exposure compensation in which the brightness of the whole image is increased. The areas of the image not illuminated by the flash remain unchanged, only the exposure for the subject illuminated by the flash is compensated.

Selectable Metering

In addition to the normal 25-segment Metering, Center Weighted Average Metering and Spot Metering may be selected with the script to suit the application or purpose.

AE Lock Selectable

A script may be used to select whether lightly pressing the shutter button is to lock or not lock (focus lock only) AE.

Manual White Balance Adjustment

White balance may be manually adjusted for red, blue, and green using a script. This function allows fine setting of white balance as necessary to suit photographic requirements.

Manual Focus

Focus may be adjusted with the cross-hairs keys (right and left) using a script. The focus may be checked on the LCD monitor for live images (this is not possible in the viewfinder). Manual focusing is not possible when digital magnification is selected.

- If you are interested in preparing your own scripts, download the Digita Script Software Development Kit from <http://www.flashpnt.com/>.
- The content of some scripts may result in problems with operation of the camera after the script has been run.
- Minolta takes no responsibility for the results of running a custom script, and is not liable for compensation for losses (e.g. loss of image data) incurred as a result of running such a script.

8. THE BRACKETING INCREMENTS HAS BEEN CHANGED

(see User's Manual P56)

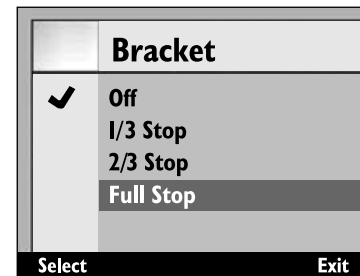

Steps used with flash bracketing with normal light were 1/2 of EV steps, however this has been changed to 1/3 of EV steps in Version 2.